

DRAWING PACKAGE

MULTI — FUNCTION

MACHINE

<i>51000</i>	<i>TOP ASSEMBLY</i>
<i>51100</i>	<i>TOWER</i>
<i>51200</i>	<i>BASE</i>
<i>51300</i>	<i>ARM</i>
<i>51400</i>	<i>BENCH</i>
<i>51500</i>	<i>YOKE</i>
<i>51600</i>	<i>BACK</i>
<i>51700</i>	<i>SEAT</i>
<i>51800</i>	<i>SHROUD</i>

REVISIONS			
REV	DESCRIPTION	DATE	APPROVED
A2	MODIFIED AFTER PRO-TOTYPE BUILD	12/7/90	HEWITT

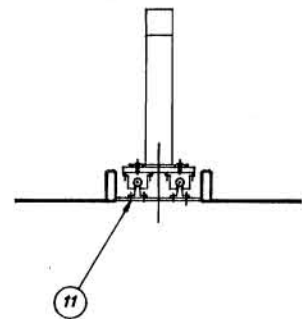
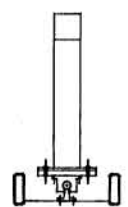
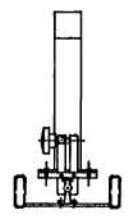
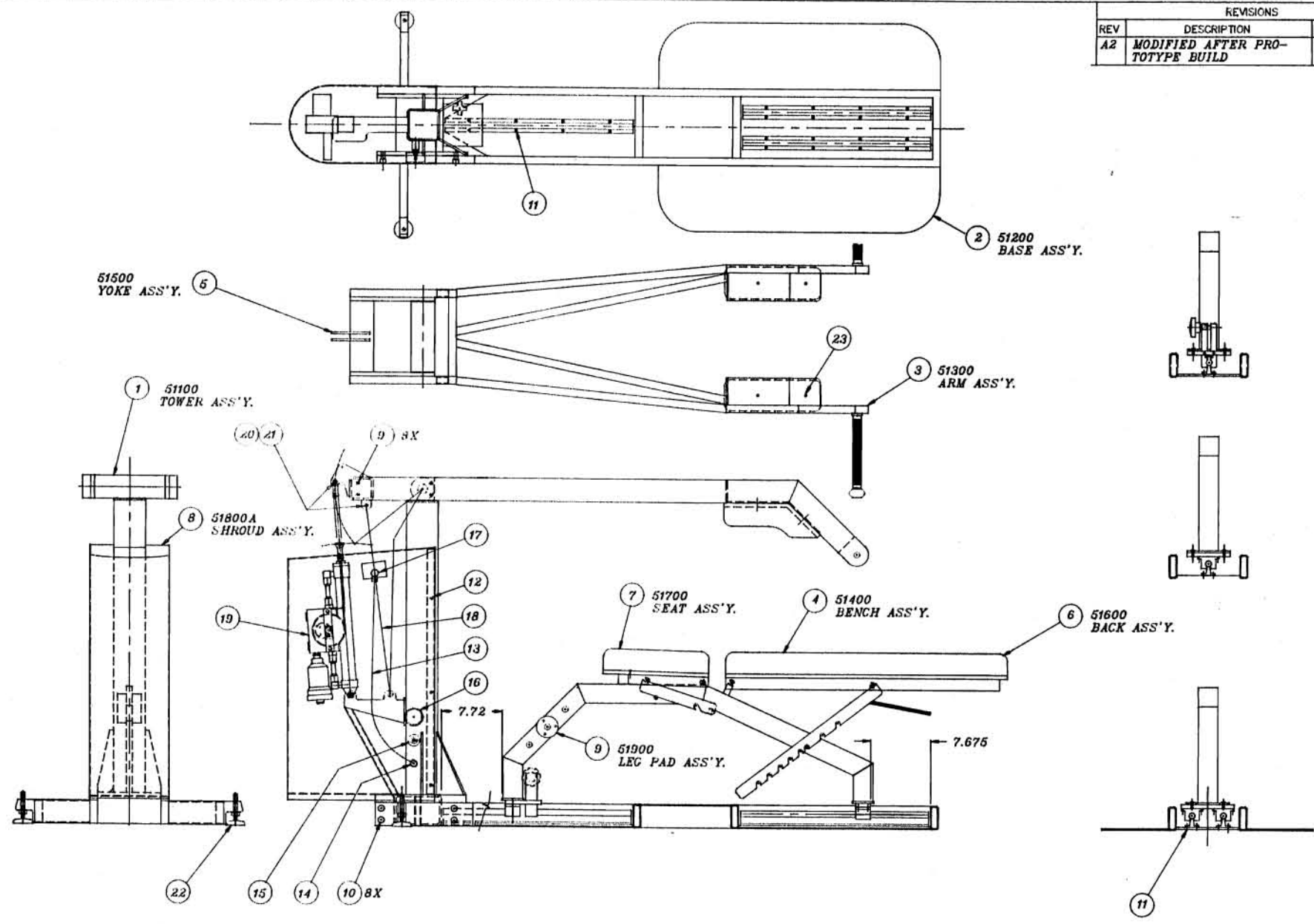

APPROVALS		DATE	TITLE	DRAWING NO.		REV
HEWITT		8/90	M/F ASS'Y. MOD.2	51000		A2
HEWITT		8/90	SCALE: C	SHEET 1		OF 3
DO NOT SCALE DRAWING		SCALE:	FILE NAME: 51000	SHEET 1		OF 3

TOLERANCES:
 FINISH:
 DIMS: .015
 Holes: .015
 ANGLES: 8.0°
 CHAMFER: .015 x 45°
 PLATING: .002
 SURFACE: .0008
 FINISH: .0008

ARIEL LIFE SYSTEMS INC.
 10110 SORRENTO VALLEY RD.
 S.D., CA. 92121 (619) 455-5952

REVISIONS		
REV	DESCRIPTION	DATE

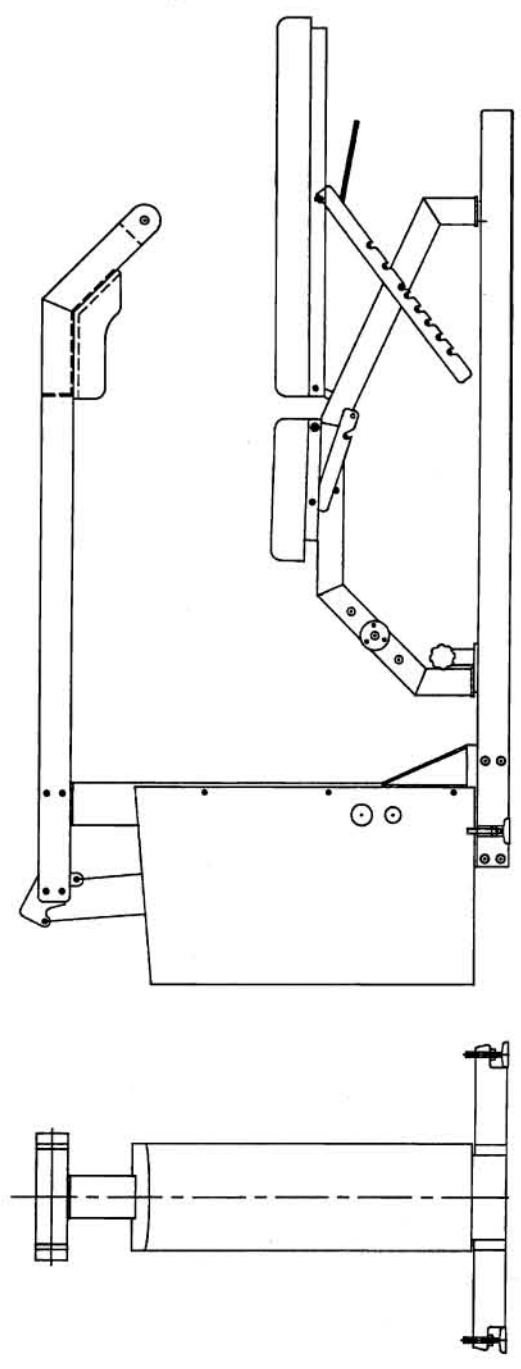
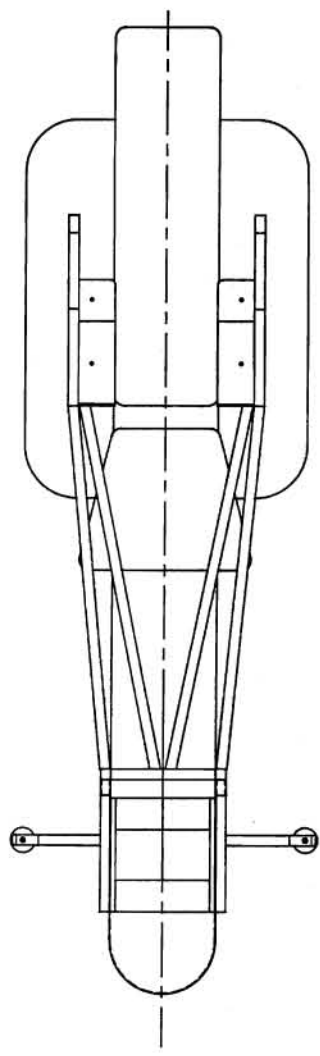

LIFE SYSTEMS INC. 1010 SORRENTO VALLEY RD. S. D. CA. 92121 (619) 466-5962		TITLE M/F ASS'Y. MOD. 2	
APPROVALS	DATE	DRAWING NO.	REV.
HEWITT	8/80	C	A2
DESIGNED BY	HEWITT	SCALE	51000 A
DO NOT SCALE DRAWING		SHEET NO.	2 OF 2
TELEPHONE: 408/466-5962 FAX: 408/466-5963 MAILING: 408/466-5963 TELEX: 350000 LIFE S Y INC			

REVISIONS			
REV	DESCRIPTION	DATE	APPROVED

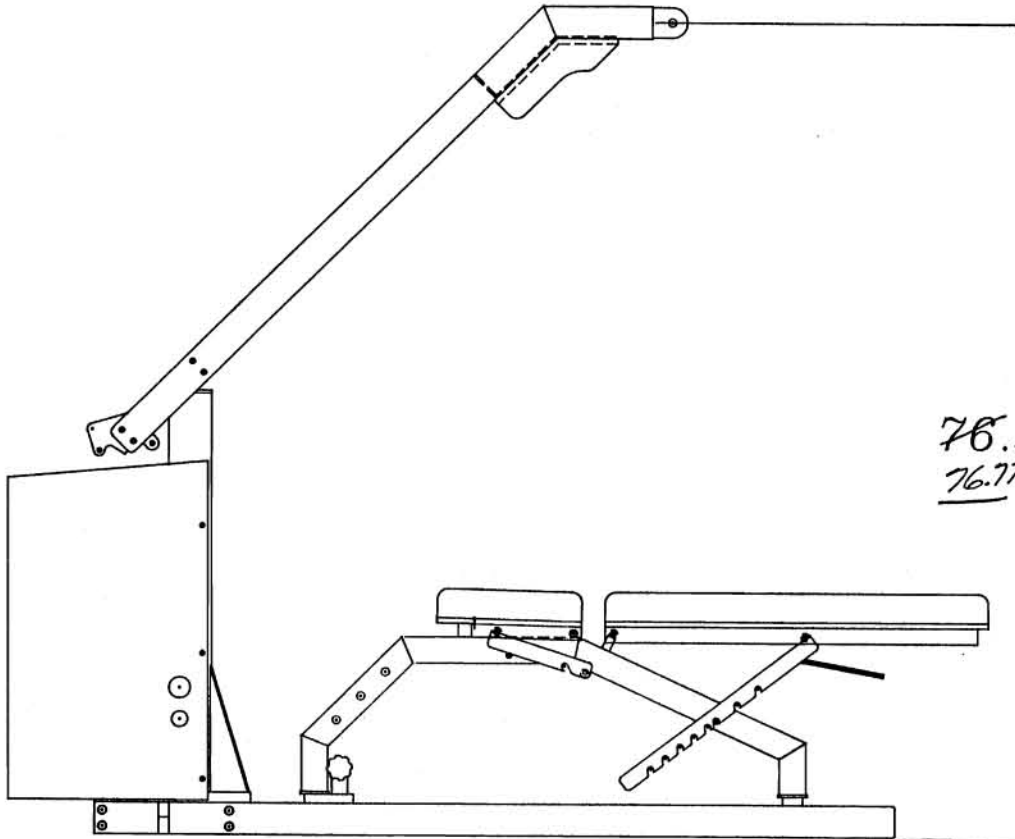

76.873
76.77

30			
29			
28			
27			
26			
25	4	FLAT WASHER 1/4" BLACK	
24	4	LOCKWASHER 1/4"	
23	4	BHCS 1/4"-20 X 1 1/4" LG. BLACK	
22	2	FOOT PAD 1/2-13 SUNNEX #2254SS	
21	2	NUT NYLOCK 7/16"-14	
20	2	SHCS 7/16"-14 X 1 1/2" LG. BLACK	
19	1	PACK ASSY. ARIEL # 90000	
18	1	AIR CYL. 2.50" BORE 5/8" ROD 12" ST. PARKER #BB-2AUS14A	
17	1	FITTING 90° SWIVEL 3/8" MPT X 1/4" FE. PM #GF06540	
16	1	AIR GAUGE 100PSI 1/4" MPT USC #AU-2457-FK	
15	1	SCHRADER VALVE 1/4" MALE MEYER TYRE # 1498E-6	
14	1	ELBOW 1/4" MALE TO 1/4" FEMALE PARKER # 4-6FU-M	
13	1	AIR HOSE ASS'Y. S.D. VALVE # S-7R4PM4PM4-25	
12	6	BHCS # 10-32 X 1/2" LG. BLACK	
11	24	SHCS # 10-24 X 1/2" LG. BLACK	
10	16	SHCS 1/2-13 X 1" LG. BLACK	
ITEM NO.	QTY REQD	PART OR IDENTIFYING NO.	DESCRIPTION

BILL OF MATERIALS

MATERIAL	PARTS		ARIEL LIFE SYSTEMS INC. 10110 SORRENTO VALLEY RD. S.D.C.A. 92121 (619) 455-5952	
DATE	APPROVALS	DATE	TITLE:	
	HEWITT	8/90	M/F ASS'Y. MOD.2	
UNLESS OTHERWISE NOTED ALL DIMENSIONS ARE IN INCHES	DESIGNED BY	HEWITT	SIZE	SCM NO.1
TOLERANCES	APPROVED	HEWITT	C	DRAWING NO. 51000
LINEAR .004 .010 ANGLES & R.F. .002				REV. 1A7
HOLE .002 .005 FLATNESS & .005				DO NOT SCALE DRAWING
HOLES .002 ROUNDNESS & .006			SCALE:	51000 SHEET 3 OF

REVISIONS			
REV	DESCRIPTION	DATE	APPROVED
A1	SH. 1; 1.500 WAS 2.00. SH. 5; REVISED ITEM 10 FOR METAL ENCLOSURE REVISED CYL. MT. PL. DET. 3&5 ADDED DET. 14	10/25	HEWITT
A2	MODIFIED TO LIGHTEN STRUCTURE; 26.44 DIM WAS 26.57	12/10	HEWITT

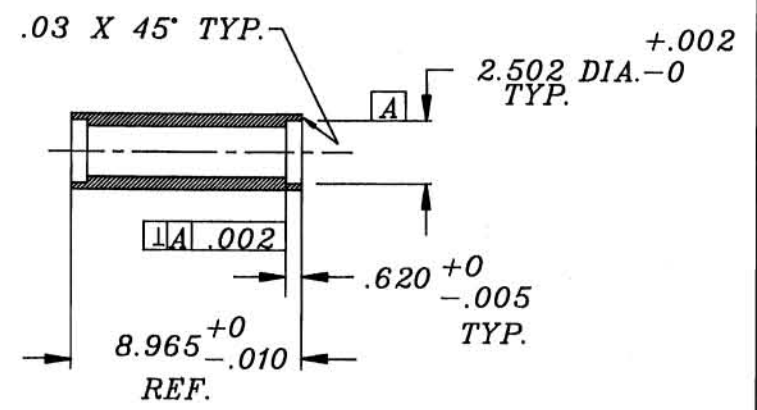
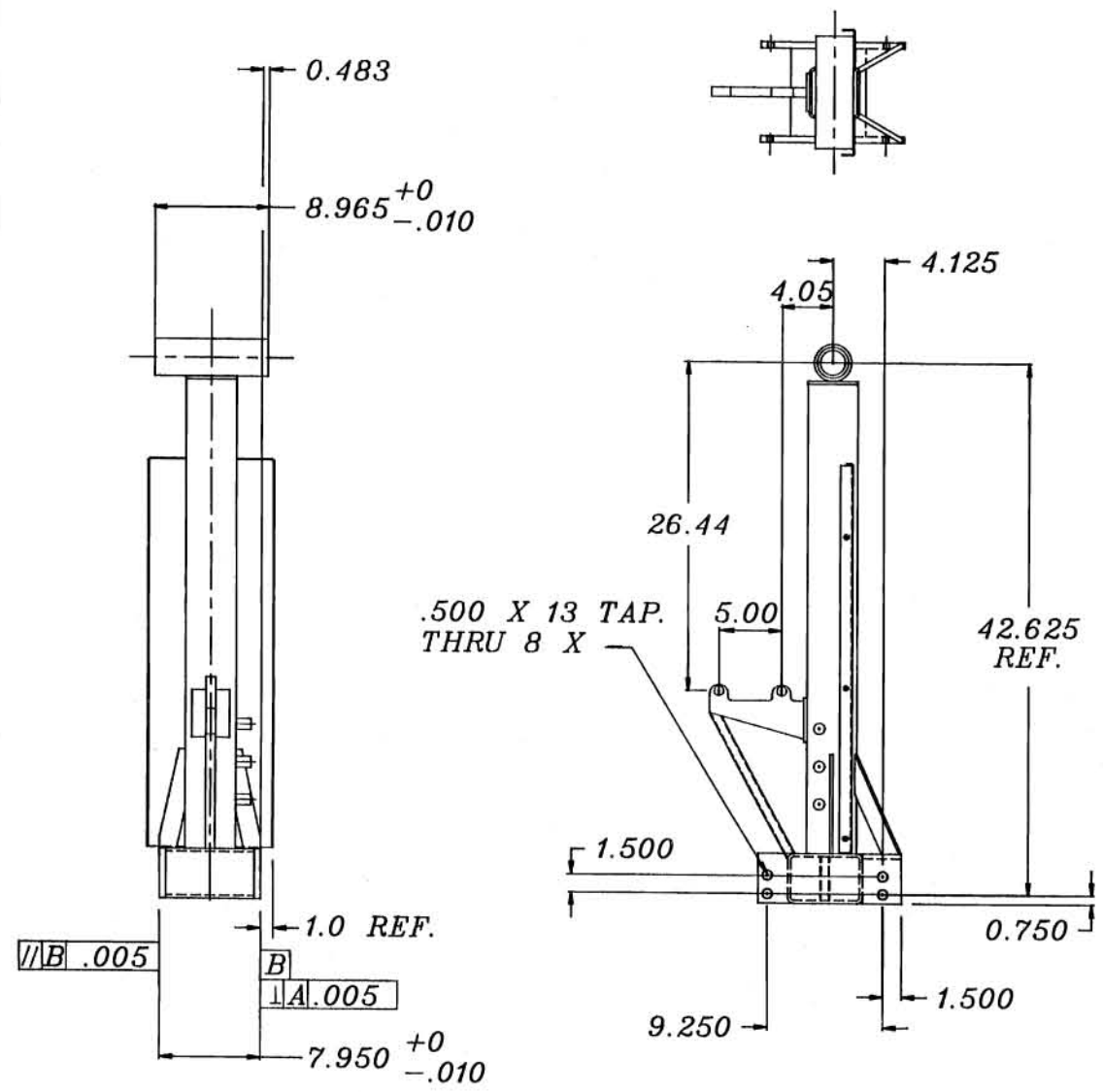

DETAIL OF BEARING HOUSING

		ARIEL LIFE SYSTEMS INC. 10110 SORRENTO VALLEY RD. S.D. CA. 92121 (619) 455-5952	
APPROVALS	DATE	TITLE	
HEWITT	8/80	M/F TOWER	
DESIGNED BY	DATE	SIZE	FORM NO.
HEWITT	8/80	C	51100
DRAWING NO.		REV.	
51100		A2	
DO NOT SCALE DRAWING		SCALE:	SHEET 1 OF 7

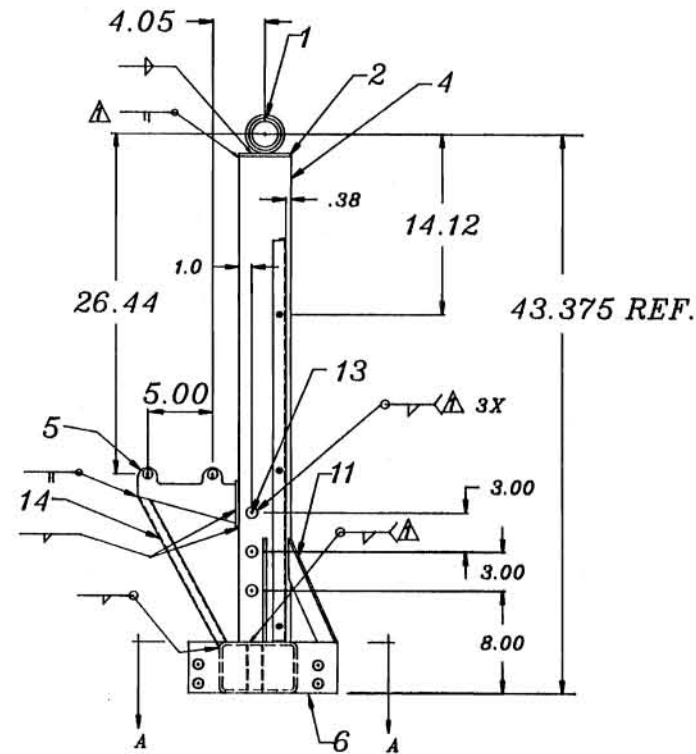
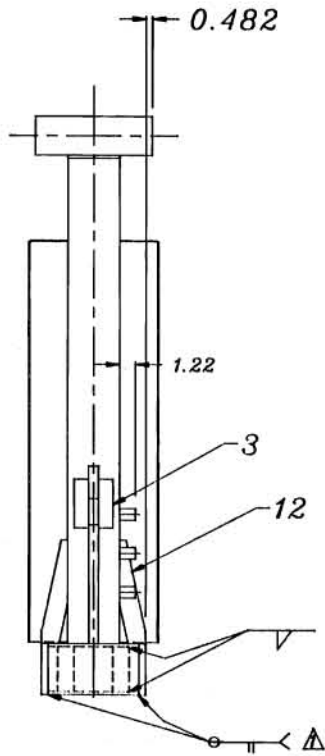
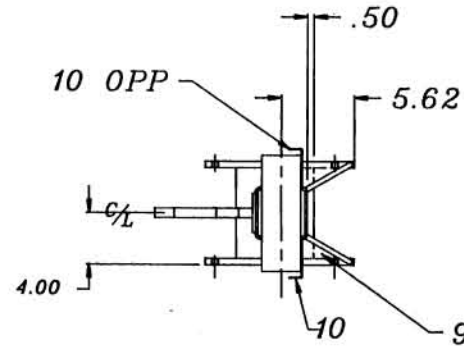
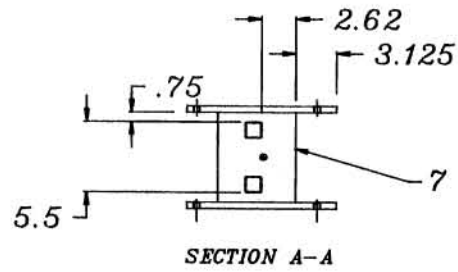

NOTE:
 ▲ PRESSURE CHECK WELDS NOTED
 FOR 100 P.S.I. WITH NO VISIBLE
 LEAKS

		LIFE SYSTEMS INC. 10110 SORRENTO VALLEY RD. S.D.C.A. 92121 (619) 455-5962	
APPROVALS		DATE	TITLE
HEWITT		8/90	M/F TOWER
HEWITT		8/90	SIZE: SCOM NO. DRAWING NO.
TOLERANCES		ANGLES & G/F	REV. 1
UNLESS	OTHER	CONCENTRICITY & .005	51100
.005 & .005	FLATNESS & .005	3000 & .005	ROUNDEDNESS & .005
DO NOT SCALE DRAWING		SCALE:	SHEET: 2 OF
		DWG NUMBER 51100	

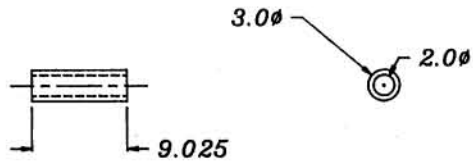

1 MAT'L. 3"OD. X .5 WALL SEAMLESS TUBE
1 REQ'D.

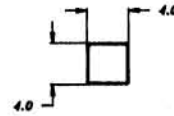

4 MAT'L. 4" SQ. X .125 WL. TUBE
1 REQ'D.

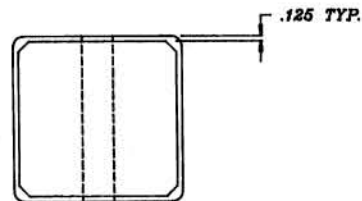
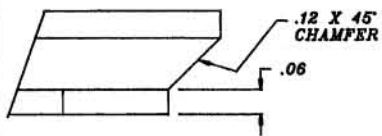
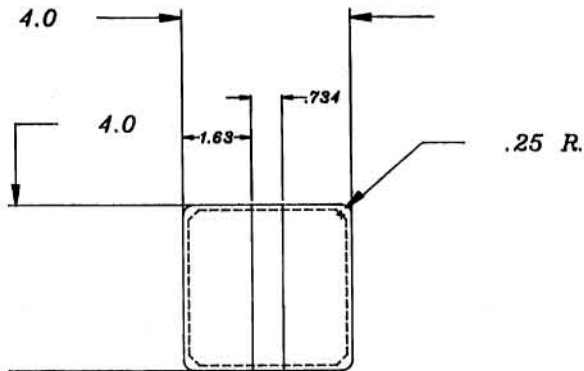

2 MAT'L. .25" PLATE 4" X 4" HR. STEEL
1 REQ'D.

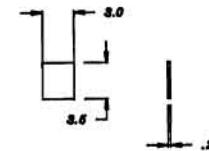

3 MAT'L. .25 HTK. X 3 X 3.5 C. R. STEEL
1 REQ'D.

		ARIEL LIFE SYSTEMS INC. 10110 SORRENTO VALLEY RD. S.D., CA. 92121 (619) 456-5982	
APPROVALS	DATE	TITLE	
HEWITT	8/90	M/F ASS'Y. MOD.2	
HEWITT	8/90	SIZE	DRAWING NO.
		C	51100
DO NOT SCALE DRAWING		SCALE:	REV. 1
		REV. 2	42
		REV. 3	
		REV. 4	
		REV. 5	
		REV. 6	
		REV. 7	
		REV. 8	
		REV. 9	
		REV. 10	
		REV. 11	
		REV. 12	
		REV. 13	
		REV. 14	
		REV. 15	
		REV. 16	
		REV. 17	
		REV. 18	
		REV. 19	
		REV. 20	
		REV. 21	
		REV. 22	
		REV. 23	
		REV. 24	
		REV. 25	
		REV. 26	
		REV. 27	
		REV. 28	
		REV. 29	
		REV. 30	
		REV. 31	
		REV. 32	
		REV. 33	
		REV. 34	
		REV. 35	
		REV. 36	
		REV. 37	
		REV. 38	
		REV. 39	
		REV. 40	
		REV. 41	
		REV. 42	
		REV. 43	
		REV. 44	
		REV. 45	
		REV. 46	
		REV. 47	
		REV. 48	
		REV. 49	
		REV. 50	
		REV. 51	
		REV. 52	
		REV. 53	
		REV. 54	
		REV. 55	
		REV. 56	
		REV. 57	
		REV. 58	
		REV. 59	
		REV. 60	
		REV. 61	
		REV. 62	
		REV. 63	
		REV. 64	
		REV. 65	
		REV. 66	
		REV. 67	
		REV. 68	
		REV. 69	
		REV. 70	
		REV. 71	
		REV. 72	
		REV. 73	
		REV. 74	
		REV. 75	
		REV. 76	
		REV. 77	
		REV. 78	
		REV. 79	
		REV. 80	
		REV. 81	
		REV. 82	
		REV. 83	
		REV. 84	
		REV. 85	
		REV. 86	
		REV. 87	
		REV. 88	
		REV. 89	
		REV. 90	
		REV. 91	
		REV. 92	
		REV. 93	
		REV. 94	
		REV. 95	
		REV. 96	
		REV. 97	
		REV. 98	
		REV. 99	
		REV. 100	

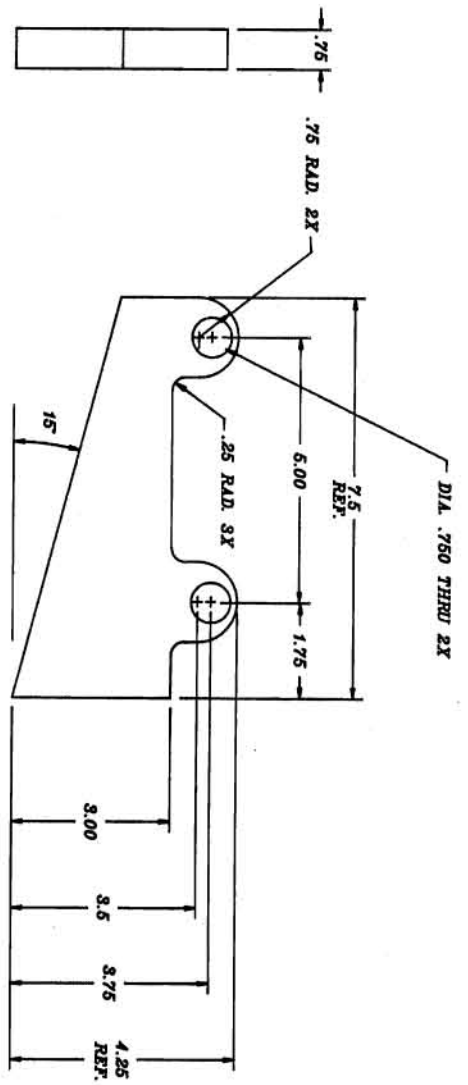

5 MAT'L. .75 X 4.25 C.R. STEEL
1 REQ'D.

6 MAT'L. 1/2" X 4" HOT ROLLED BAR
2 REQ'D.

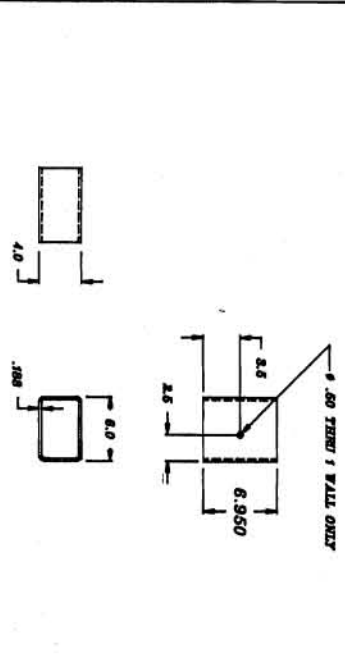
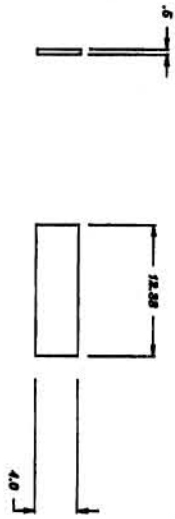

7 MAT'L. TUBE RECT. 6 X 4 X 188 WALL E.W.
12.14 # / FT.
1 REQ'D.

9 MAT'L. 18 GA. (.0478) STEEL
2 REQ'D.

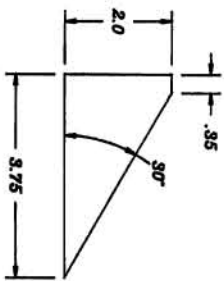

8 MAT'L. 1.25 SQ.
TUBE X .094 WALL
2 REQ'D.

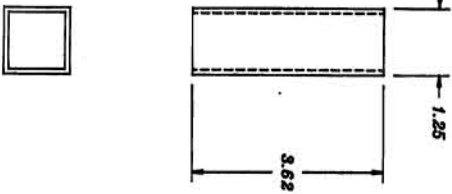

DESIGNER: ANDREW A. LEE		DATE: 8/90		TITLE: ARIEL LIFE SYSTEMS INC.	
CHECKER: JAMES W. JOHNSON		DATE: 8/90		S.D. CL. 92181 (619) 455-5982	
APPROVALS:		DATE:		PROJECT: 51100	
HEWITT		8/90		DRAWING NO: 51100A	
HEWITT		8/90		SHEET: 4	
DO NOT SCALE DRAWING		SCALE:		SHEET: 4	
SCALE:		SCALE:		SHEET: 4	

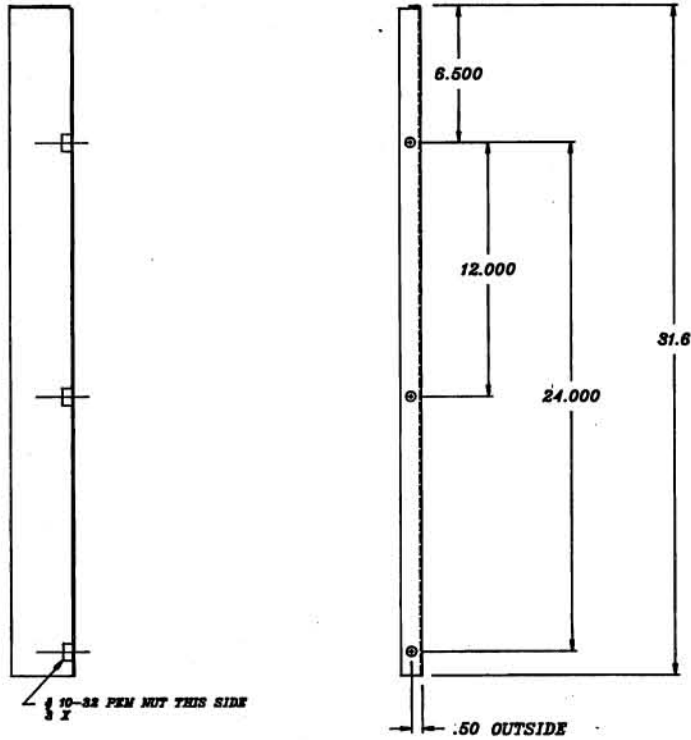
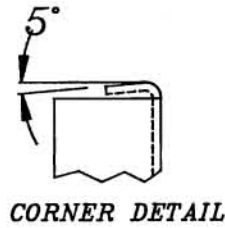
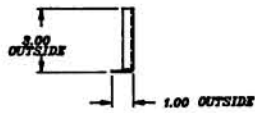

10 MAT'L 14 GA (.074) H.R. SHEET
1 REQ'D AS SHOWN, ONE OPPOSITE

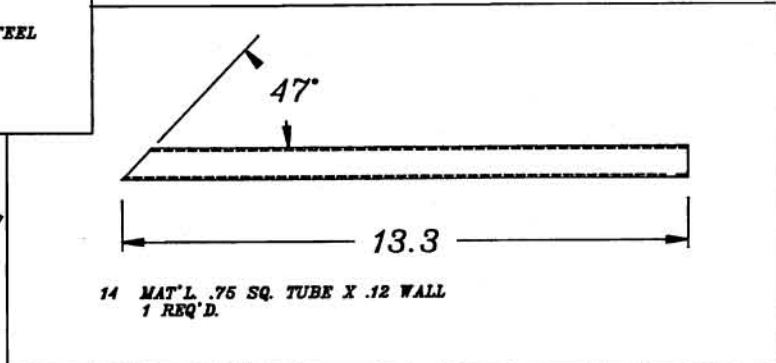
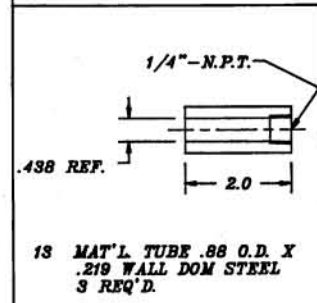
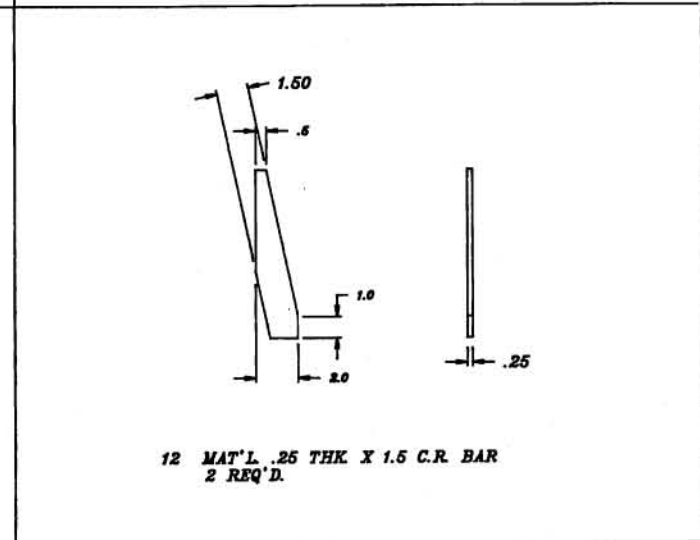
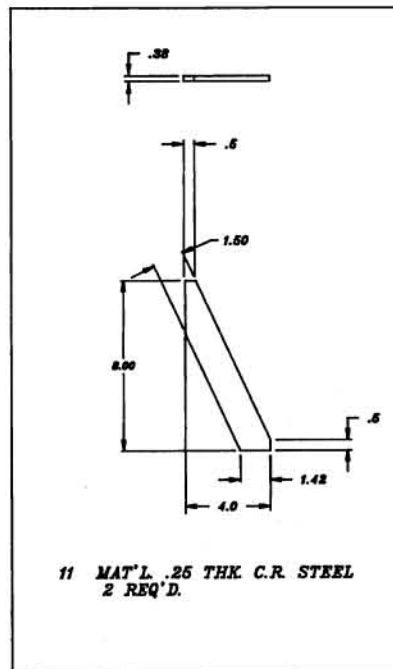

APPROVALS		DATE	TITLE	
HEWITT		8/90	M/F TOWER	
HEWITT		8/90	SCALE	REV.
C		51100	A2	
DO NOT SCALE DRAWING			SCALE	SHEET 5 OF
			51100B	

ARIEL LIFE SYSTEMS INC.
10110 SOLORENTO VALLEY RD.
S.D. CA 92121 (619) 455-6962

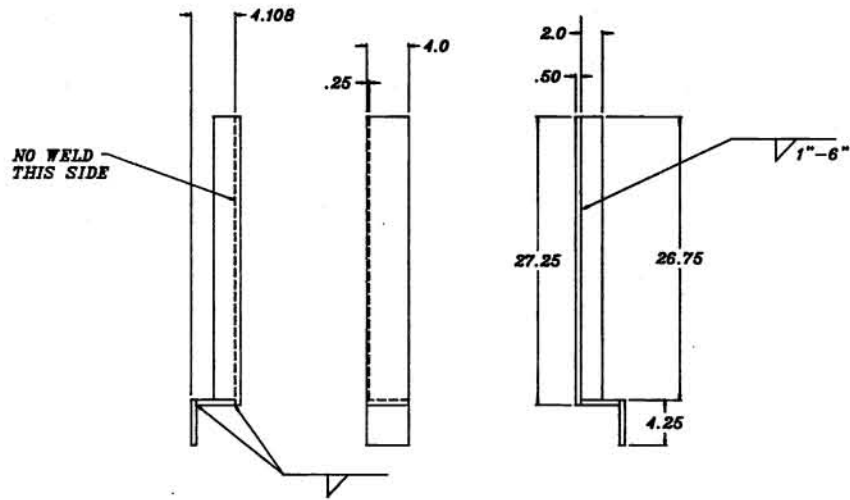

DETAIL A WELDMENT

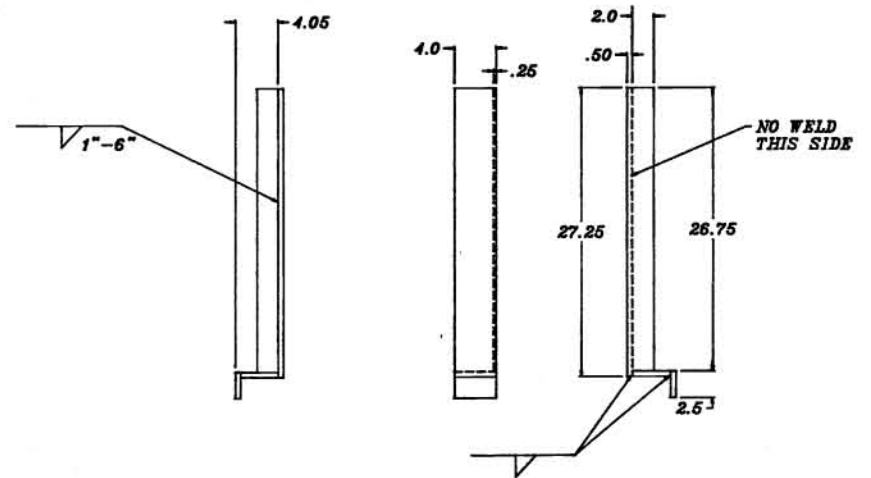

DETAIL B WELDMENT

		ARIEL LIFE SYSTEMS INC. 10110 SORRENTO VALLEY RD. S.D.CA. 92121 (818) 466-6962	
APPROVALS	DATE	TITLE	
HEWITT	3/91	M/F TOWER ALIGNMENT TOOL	
DESIGNER		SIZE	DRAWING NO.
		C	51100
TOLERANCES: ANGLES & S.P. .125 .005 CONCENTRICITY & .005 .125 .005 FLATNESS & .005 .125 .005 ROUNDNESS & .005		SCALE:	REV:
DO NOT SCALE DRAWING		SCALE:	A2
		51100C	SHEET: 6 OF:

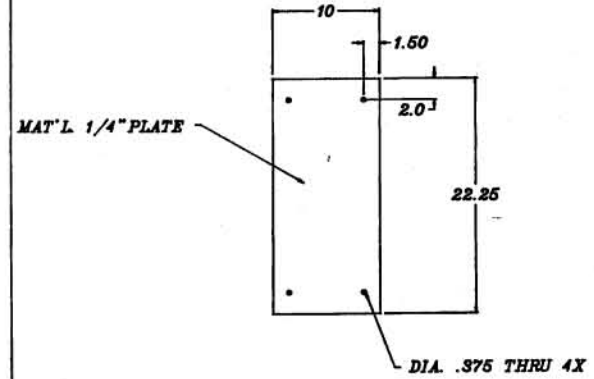
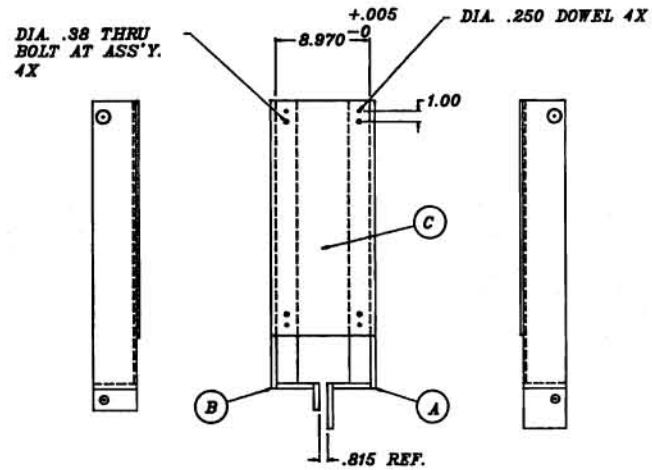
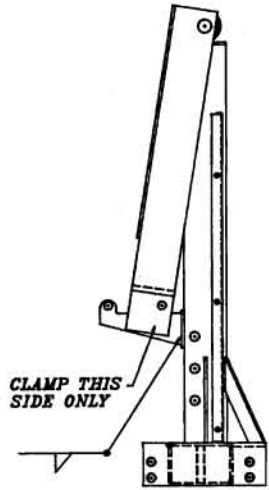

DETAIL C

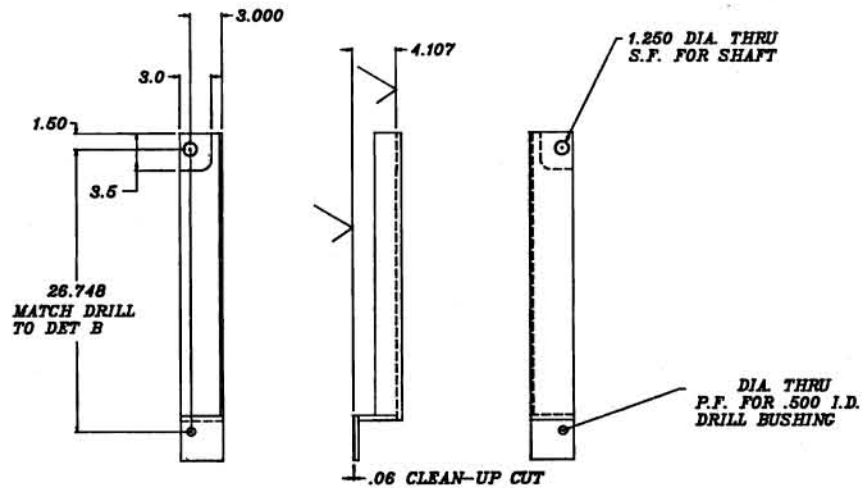

DETAIL A MACHINING

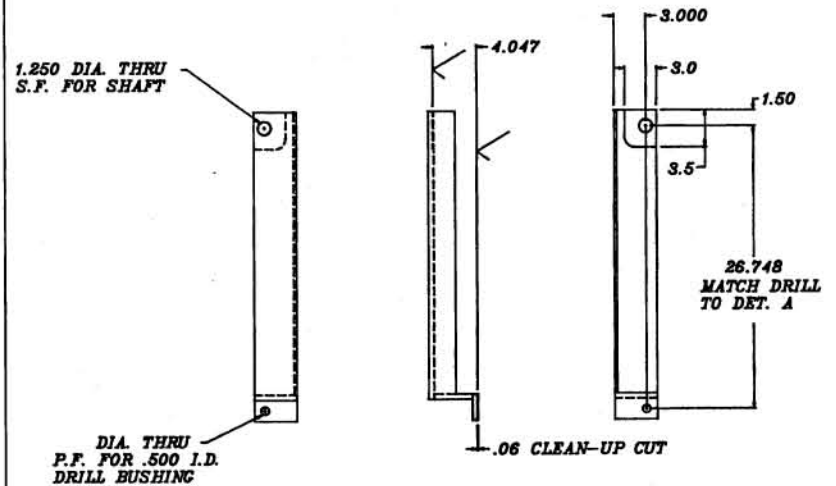

DETAIL B MACHINING

		ARIEL LIFE SYSTEMS INC. 10110 SORRENTO VALLEY RD. S.D., CA 92121 (619) 465-6962	
APPROVALS	DATE	TITLE	
HEWITT	3/91	M/F TOWER ALIGNMENT TOOL	
DESIGNER		SIZE	DRAWING NO.
		C	51100
TOLERANCES: LINEAR .001 ANGLES ± .05 HOLE .002 CONCENTRICITY ± .005 SURF .002 FLATNESS ± .005 ROUNDED .0005 ROUNDEDNESS ± .005		SHEET NO. 61100C SCALE:	SHEET 7 OF 7

REVISIONS			
REV	DESCRIPTION	DATE	APPROVED
A1	REVISED 3" TUBE WAS 3.5"	10/17/90	HEWITT
A2	MODIFIED AFTER PROTO-TYPE BUILD	12/13/90	HEWITT

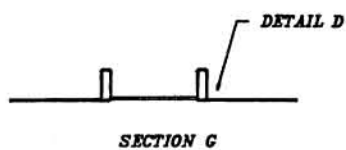
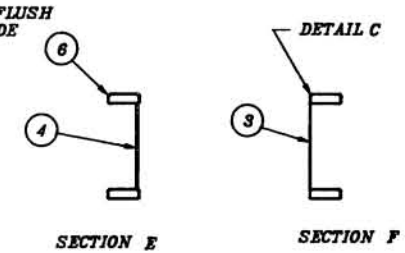
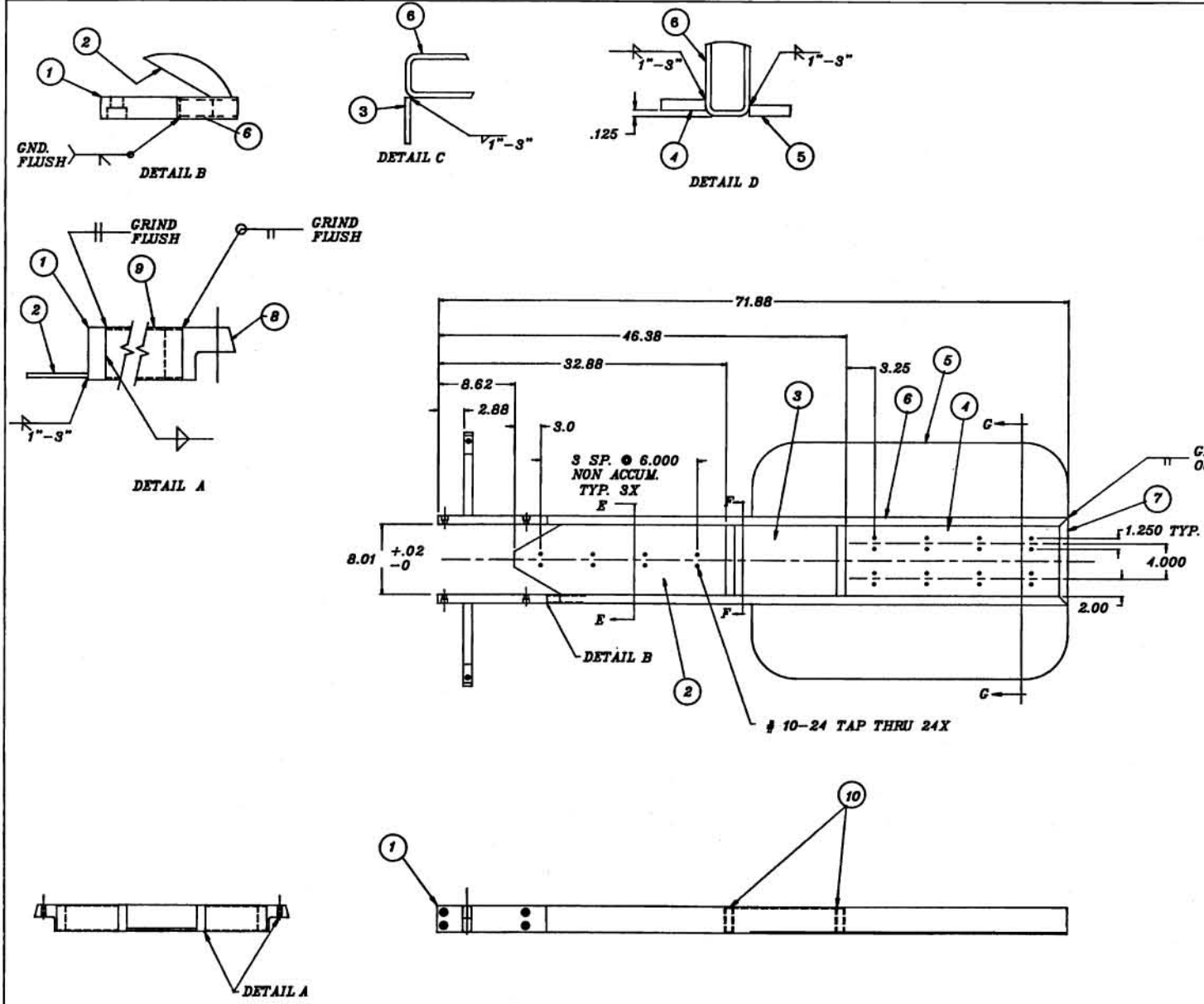

TOL .X=± .03

APPROVALS		DATE	TITLE
HEWITT		8/90	ARIEL LIFE SYSTEMS INC. 1010 SORRENTO VALLEY RD. S.D.CA. 92121 (619) 456-5962
HEWITT		8/90	M/F BASE ASS'Y.
TOLERANCES		SIZE / SCAL NO.	DRAWING NO.
LINEAR .004 .008 ANGLES & R.F. CONCENTRICITY & .008		C	51200
HOLE .002 .004 FLATNESS & .002		DO NOT SCALE DRAWING	REV: A2
ROUNDNESS & .008		SCALE:	REV: 51200 SHEET: 1 OF: 3

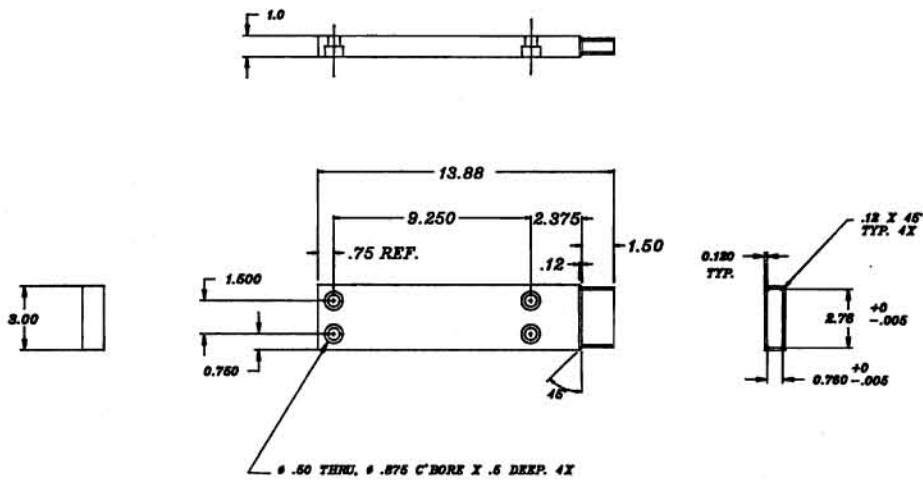

1 MAT'L. 1" X 3.0" C.R. BAR STEEL 10.2 #/FT.
2 REQ'D.

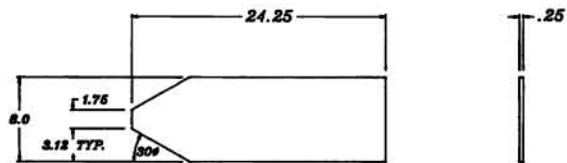

2 MAT'L. .25 X 8 C.R. BAR 6.8#/ FT.
1 REQ'D.

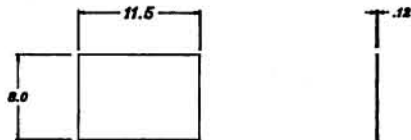

3 1/8" FLOOR PLATE, STEEL 6.15#/ SQ. FT.
1 REQ'D.

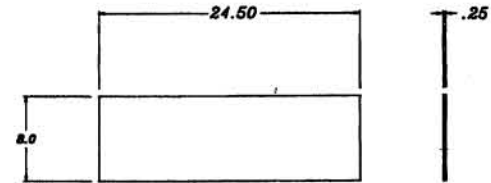

4 MAT'L .25 X 8 C.R. STEEL 6.8#/ FT.
1 REQ'D.

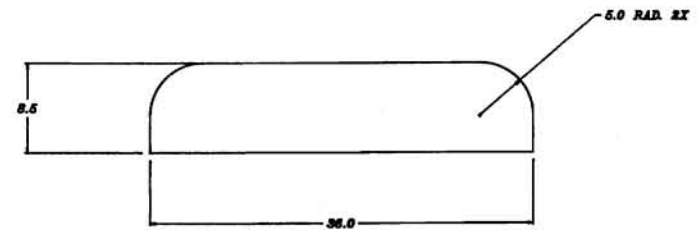

5 MAT'L .188 FLOOR PLATE 8.71#/SQ. FT.
2 REQ'D.

TOL .X=± .03

APPROVALS		DATE	TITLE	
HEWITT		8/90	M/F BASE ASS'Y.	
HEWITT		8/90	SIZE	DRAWING NO.
		C	51200	REV: A2
DO NOT SCALE DRAWING			SCALE:	SHEET: 2 OF:

ARIEL LIFE SYSTEMS INC.
1010 SORRENTO VALLEY RD.
S.D.C.A. 92121 (619) 455-5952

DIMENSIONS ARE IN:
LINEAR: MILLIMETERS & 0.1"
HOLE: DIA CONCENTRICITY & .008
HOLE DIA FLATNESS & .005
HOLE DIA ROUNDNESS & .005

51200 SHEET: 2 OF:

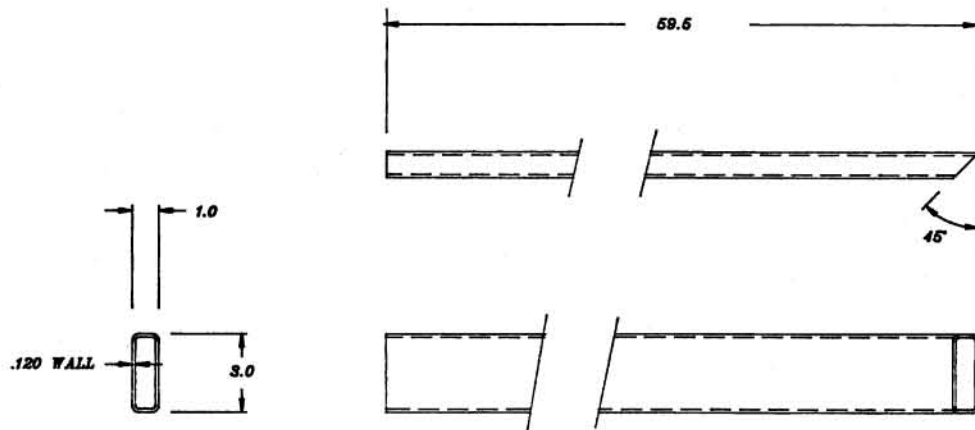

⑥ MAT'L TUBE 1" X 3.0" X .120 WALL E.W. STEEL 3.07# / FT.
2 REQ'D.

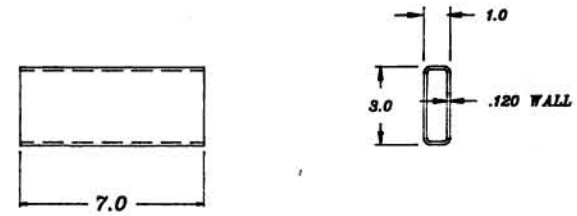

⑨ MAT'L TUBE 1" X 3" X .120 WALL
E.W. STEEL 3.07# / FT.
2 REQ'D.

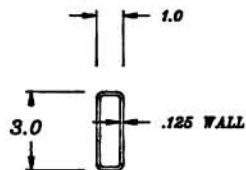
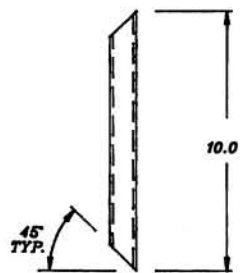

⑦ MAT'L TUBE 1" X 3.0"
X .120 WALL E.W.
STEEL 3.07 # / FT.
1 REQ'D.

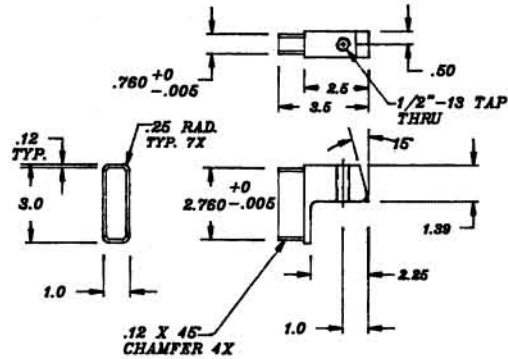

⑧ MAT'L 1 X 3 C.R. STEEL
2 REQ'D.

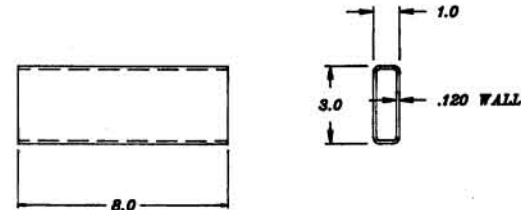

⑩ MAT'L TUBE 1" X 3" X .120 WALL
E.W. STEEL 3.07# / FT.
2 REQ'D.

TOL. .X=± .03

		APPROVALS		DATE	TITLE	
		HEWITT		8/90	M/F BASE ASS'Y.	
		HEWITT		8/90	SIZE: F35M HOLE	DRAWING NO.:
					C	51200
TOLERANCES:		ANGLES & S.P.		REV.:		
LINEAR:		CONCENTRICITY & .005		A2		
HOLE:		FLATNESS & .005		SCALE:		
ROUNDNESS & .005		DO NOT SCALE DRAWING		SCALE:		
		SHEET: 3		OF:		

ARIEL LIFE SYSTEMS INC.
10110 SORRENTO VALLEY RD.
S.D.CA. 92121 (619) 455-5952

51200

REVISIONS			
REV	DESCRIPTION	DATE	APPROVED

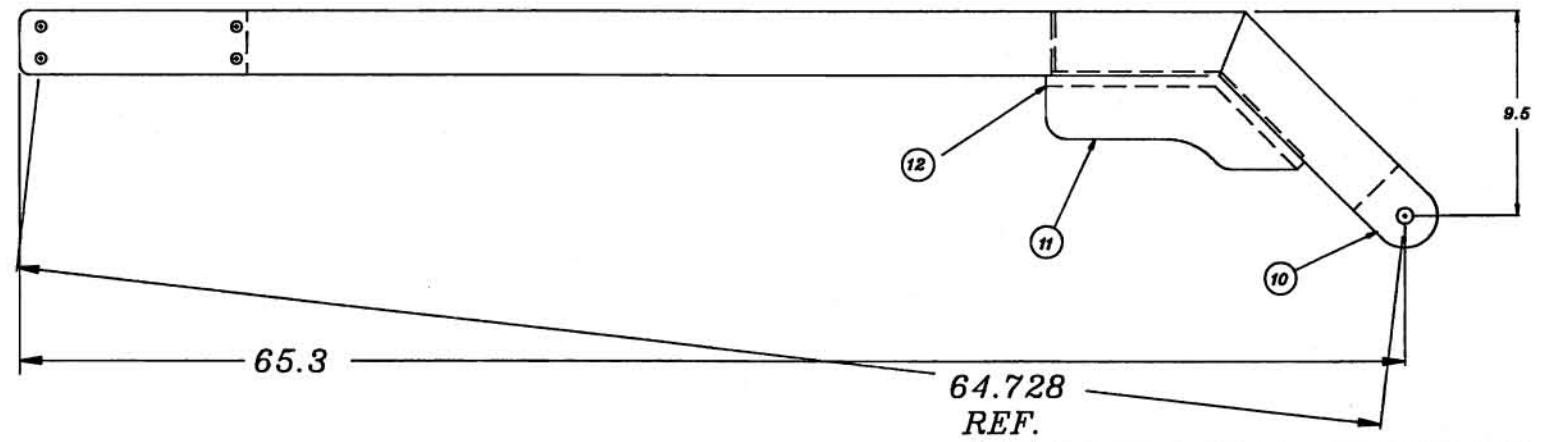
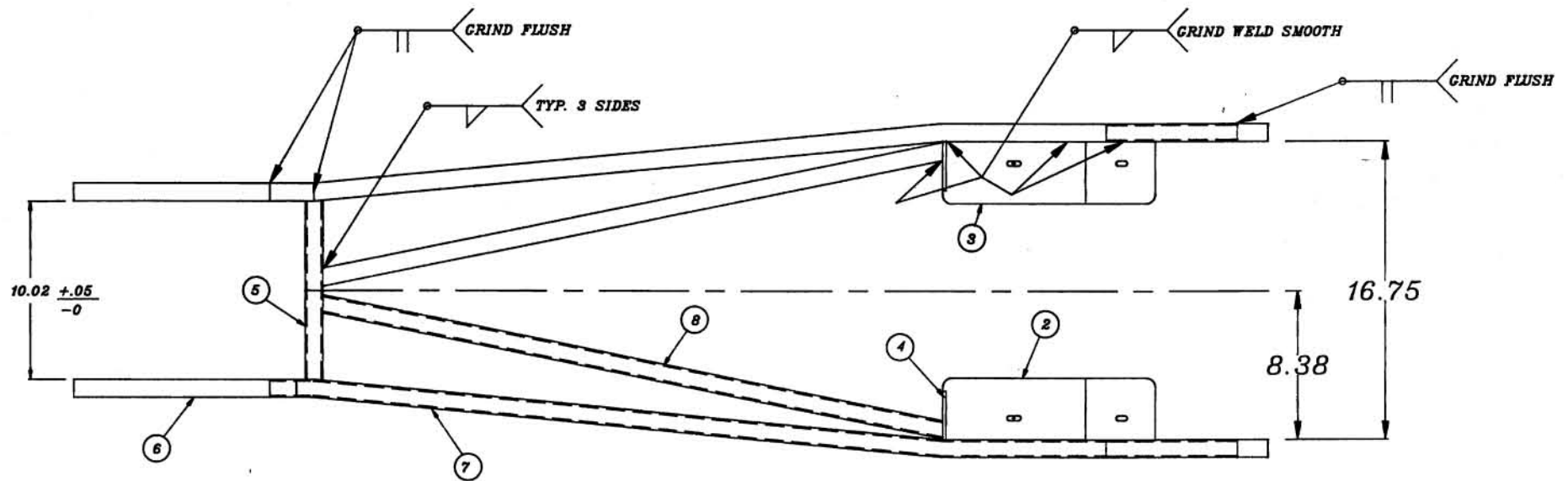

APPROVALS		DATE	TITLE	
HEWITT		8/90	M/F ARM ASS'Y.	
HEWITT		8/90	SIZE: C	DRAWING NO: 51300
TOLERANCES		UNLESS OTHERWISE SPECIFIED	REV: A2	REV: A2
LINEAR	.254 .010	ANGLES & SPT	DO NOT SCALE DRAWING	SCALE: 1:1
	.0025 .005	CONCENTRICITY & JES		
	.0025 .005	FLATNESS & POS		
	.0025 .005	ROUNDNESS & POS		

ARIEL LIFE SYSTEMS INC.
10110 SORRENTO VALLEY RD.
S.D.C.A. 92121 (619) 465-6962

DO NOT SCALE DRAWING SCALE: 1:1 SHEET: 1 OF: 5

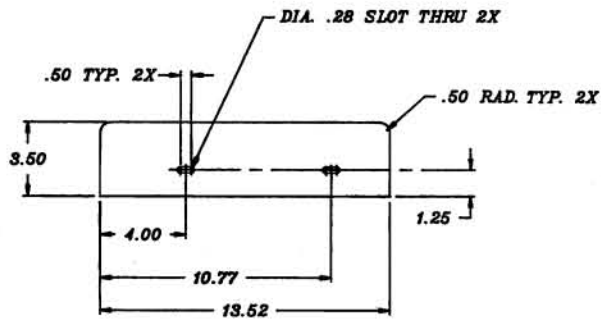

① MAT'L BAR .188 X 3.50 C.R. STEEL
2 REQ'D.

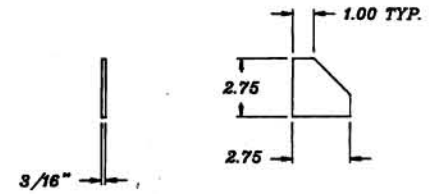

④ MAT'L BAR .188 X 2.75 C.R. STEEL
2 REQ'D.

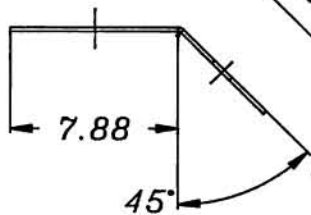
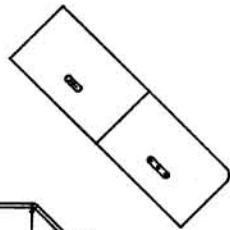
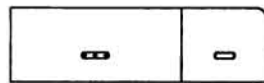

② MAKE FROM ①
1 REQ'D.

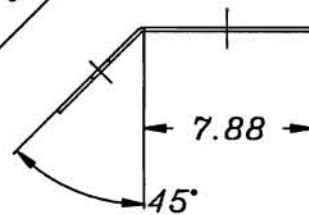
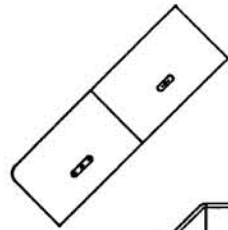
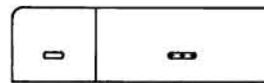

③ MAKE FROM ①
1 REQ'D.

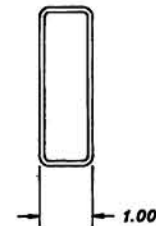
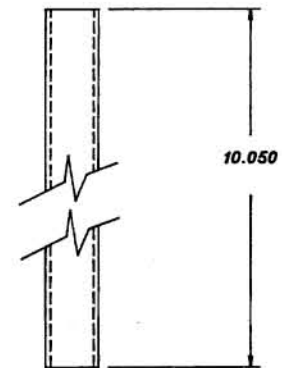

⑤ MAT'L TUBE 1 X 3 X .094 WALL E.W.
1 REQ'D.

APPROVALS		DATE	TITLE	
HEWITT		8/90	M/F ARM ASS'Y.	
HEWITT		8/90	SIZE: 1/8" DIA. HOLE	DRAWING NO: 51300
TOLERANCES: UNLESS OTHERWISE SPECIFIED		SCALE: 1" = 1"	REV: A2	
LINE: 200	ANILES & 0.5"			
3000	CONDUCTIVITY & .005			
3000	FLANGES & .005			
3000	ROUNDNESS & .005			
DO NOT SCALE DRAWING		SCALE: 1" = 1"	DWG NO: 51300	SHEET: 2 OF: 2

ARIEL LIFE SYSTEMS INC.
10110 SORRENTO VALLEY RD.
S.D., CA. 92121 (619) 455-6962

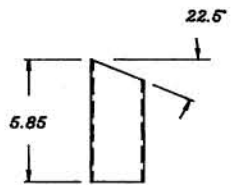

① MAT'L TUBE, 2.50" SQ. X .094 WALL
E.W. STEEL
1 REQ'D.

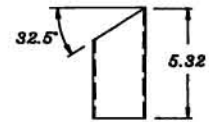

⑤ MAT'L TUBE, 2.50" SQ. X .094 WALL
E.W. STEEL
1 REQ'D.

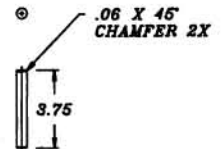

⑨ MAT'L .50 DIA. C.R.S.
1 REQ'D.

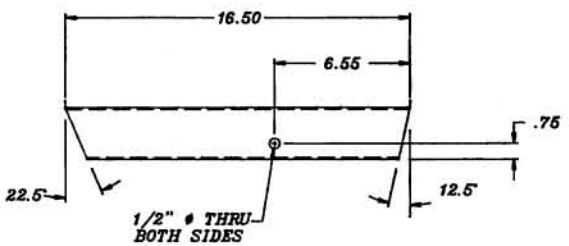

② MAT'L TUBE, 2.50" SQ. X .094 WALL
E.W. STEEL
1 REQ'D.

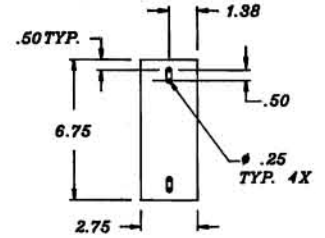

⑥ MAT'L .25" PLATE, STEEL
1 REQ'D.

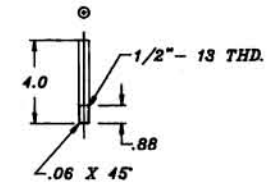

⑩ MAT'L .50 DIA. C.R.S.
1 REQ'D.

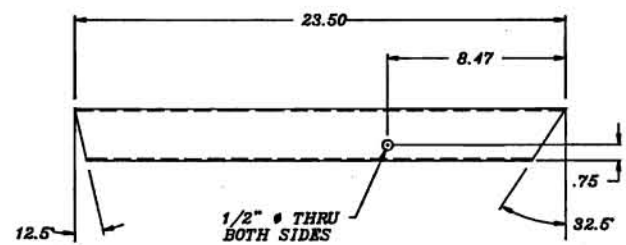

③ MAT'L TUBE, 2.50" SQ. X .094 WALL
E.W. STEEL
1 REQ'D.

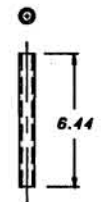

⑦ MAT'L TUBE, .688 OD. X .51 ID.
SEAMLESS STEEL
2 REQ'D.

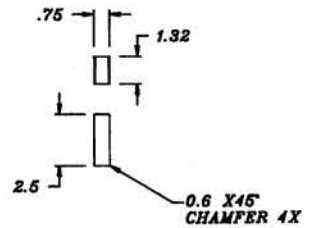

⑪ MAT'L .75 THK H.R. STEEL
1 REQ'D.

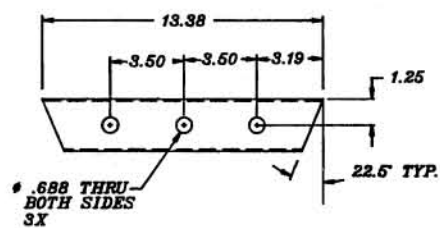

④ MAT'L TUBE, 2.50" SQ. X .094 WALL
E.W. STEEL
1 REQ'D.

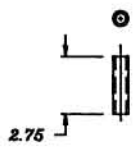

⑧ MAT'L TUBE, .688 OD. X .51 ID.
SEAMLESS STEEL
4 REQ'D.

APPROVALS		DATE	TITLE: ARIEL LIFE SYSTEMS INC. 1010 SORRENTO VALLEY RD. S.D., CA. 92121 (619) 466-6962	
HEWITT		8/90	M/F BENCH ASS'Y.	
HEWITT		8/90	SIZE: FSCM NO.1	DRAWING NO.1
DO NOT SCALE DRAWING		SCALE:	51400A	SHEET: 2 OF: 42

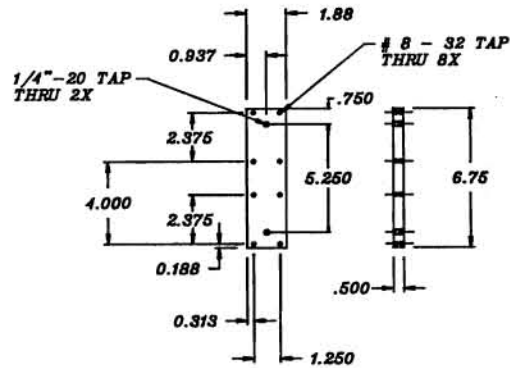

12 MAT'L 6061 -T6 ALUMINUM OR EQ.
1 REQ'D.
BLACK ANODIZE
.04 X 45° ALL HOLES

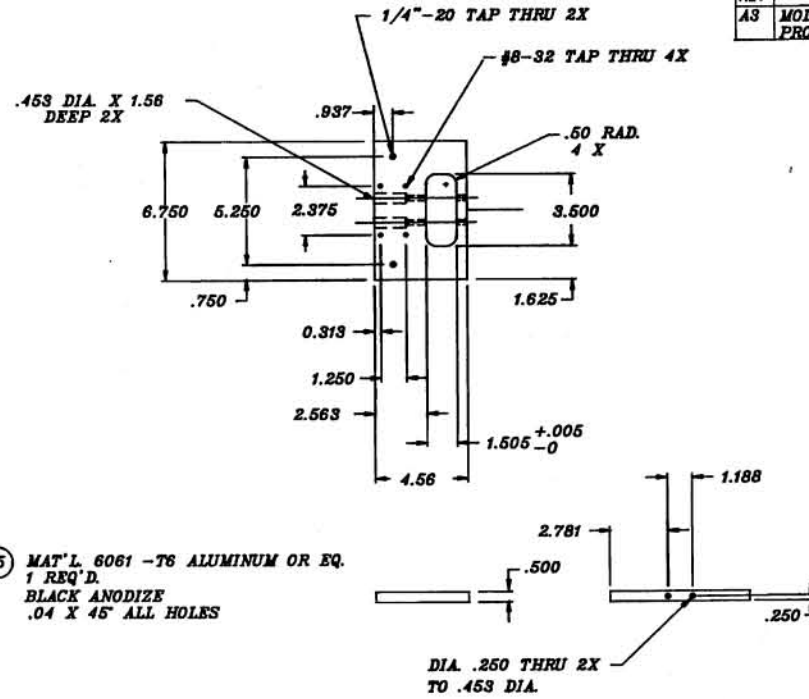

15 MAT'L 6061 -T6 ALUMINUM OR EQ.
1 REQ'D.
BLACK ANODIZE
.04 X 45° ALL HOLES

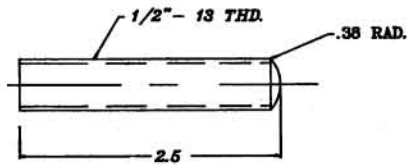

14 MAT'L 1/2"-13 STAINLESS THD. ROD
1 REQ'D.
SCALE - FULL

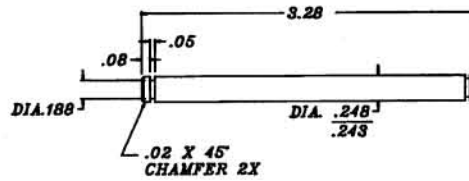

17 MAT'L 300 SERIES STAINLESS STEEL
2 REQ'D.
SCALE - FULL

REVISIONS			
REV	DESCRIPTION	DATE	APPROVED
A3	MOD. DET. 15 AFTER 25 PROD. UNITS BUILT	10/91	HEWITT

APPROVALS		DATE	TITLE	
HEWITT		8/90	M/F BENCH ASS'Y.	
HEWITT		8/90	SIZE: FROM FILE	DRAWING NO.
			C	51400
DO NOT SCALE DRAWING		SCALE:	51400B	SHEET: 3 OF

ARIEL LIFE SYSTEMS INC.
10110 SORRENTO VALLEY RD.
S.D. CA 92121 (619) 465-6962

REL TOLERANCES: ANGLES ± 0.1°
DIM. 250 CONCENTRICITY ± .005
DIM. 250 FLATNESS ± .005
DIM. 250 ROUNDNESS ± .005

.12 X 45° CHAMFER

1/2"-13 TAP THRU

5.062

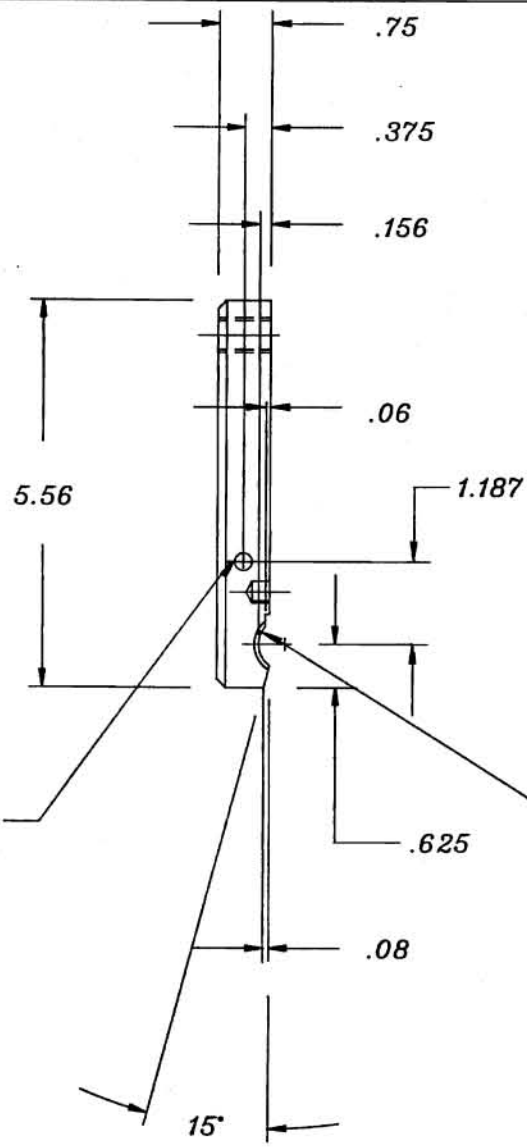
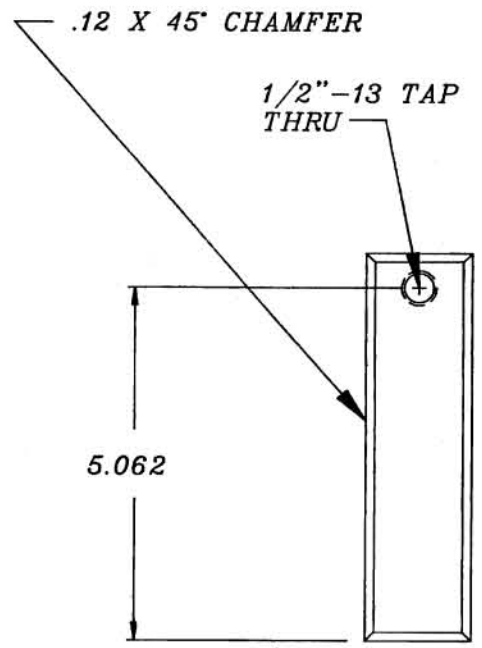

LTR. F (ø.257) THRU

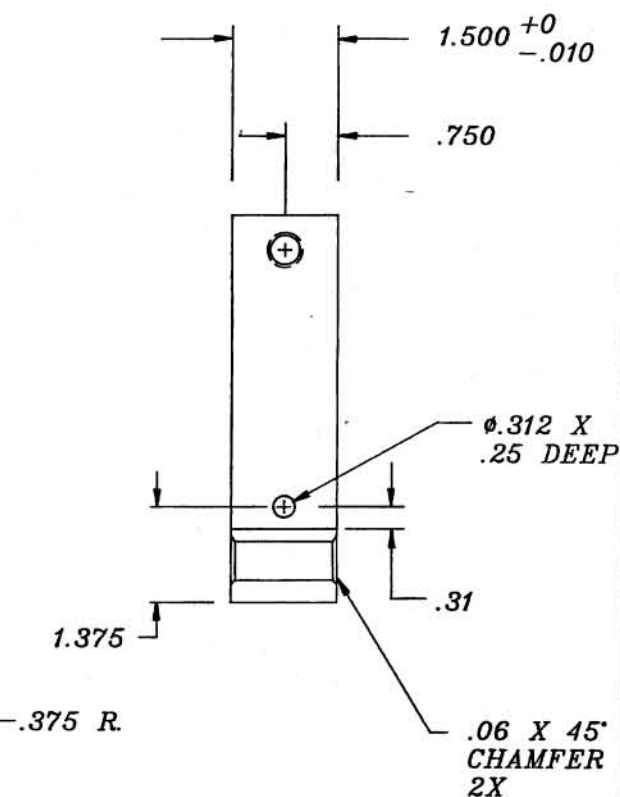

ø.312 X .25 DEEP

.06 X 45° CHAMFER 2X

13 MAT. L. 300 SERIES STAINLESS STEEL
 1 REQ. D.
 .04 X 45° ALL HOLES
 CHAMFER
 ALL AROUND MIN.

APPROVALS		DATE	TITLE	
HEWITT		8/90	M/F BENCH ASS'Y.	
HEWITT		8/90	SIZE: C	DRAWING NO.: 51400
TOLERANCES:		LINEAR: .005	ANGLES: ± .05°	CONCENTRICITY: ± .005
		ROUNDS: .005	FLATNESS: ± .005	ROUNDNESS: ± .005
DO NOT SCALE DRAWING			SCALE:	SHEET: 4 OF:

ARIEL LIFE SYSTEMS INC.
 10110 SORRENTO VALLEY RD.
 S.D. CA. 92121 (619) 455-5952

REV: A2

61400B

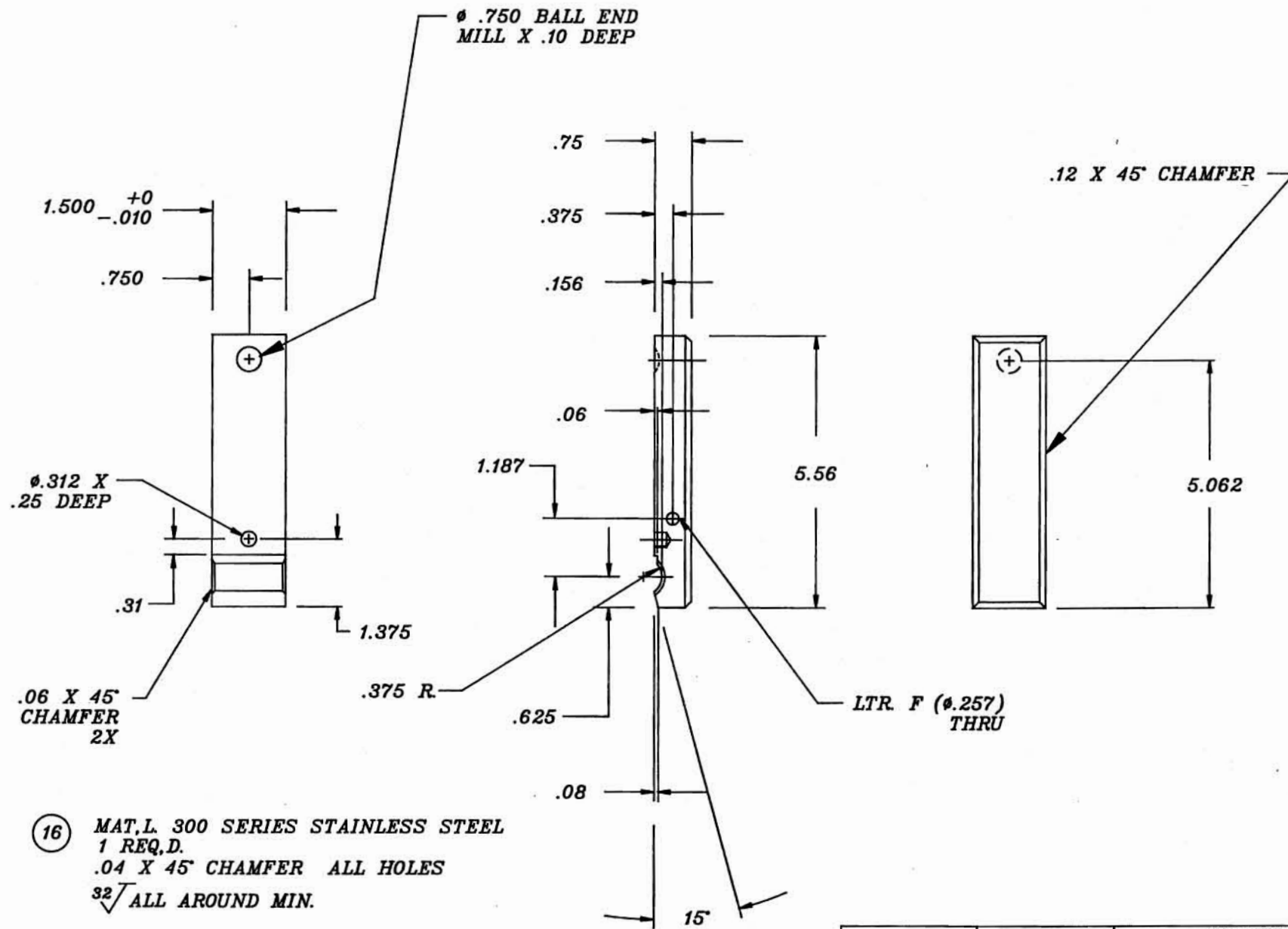

		ARIEL LIFE SYSTEMS INC. 10110 SORRENTO VALLEY RD. S.D.C.A. BEIRI (818) 465-6962	
APPROVALS	DATE	TITLE	
HEWITT	8/90	M/F BENCH ASS'Y.	
HEWITT	8/90	SIZE: FROM FILE	DRAWING NO:
		C	51400
DO NOT SCALE DRAWING		SCALE:	SHEET: 6 OF:
		51400B	

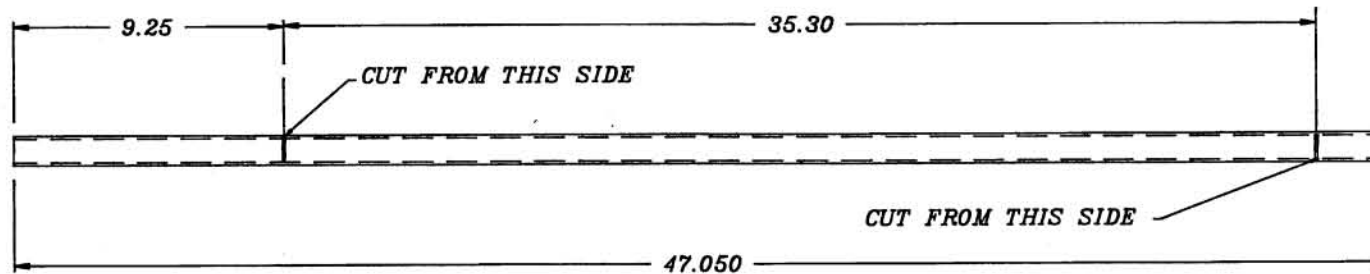
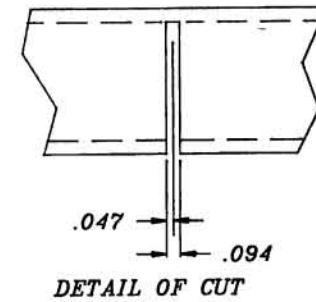
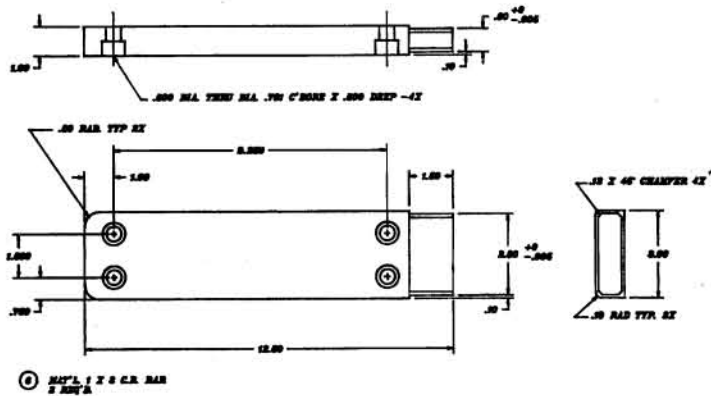

⑦ MAT'L TUBE 1 X 3 X .094 WALL EW STEEL
 1 REQ'D. AS SHOWN
 1 REQ'D. OPPOSITE

		ARIEL LIFE SYSTEMS INC. 10110 SORRENTO VALLEY RD. S.D.C.A. 92121 (818) 465-6962	
APPROVALS	DATE	TITLE: M/F ARM ASS'Y.	
HEWITT	8/90		
HEWITT	8/90	SIZE: TSCM NO.:	DRAWING NO.:
		C	51300
TELEDIMENSIONS LINEAR .001 ANGLES & R/F HOLE .002 CONCENTRICITY & .002 LOC .002 FLATNESS & .002 SURFACE .0025 ROUNDNESS & .002	APPROVED:	SCALE:	REV.:
		DO NOT SCALE DRAWING	A2
		FIG. 51300	SHEET: 3 OF:



8 MAT'L. TUBE 1 X 3 X .094 WALL EW STEEL
2 REQ'D.

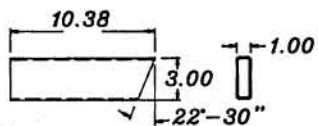

9 MAT'L. TUBE 1 X 3 X .094 WALL EW STEEL
2 REQ'D.

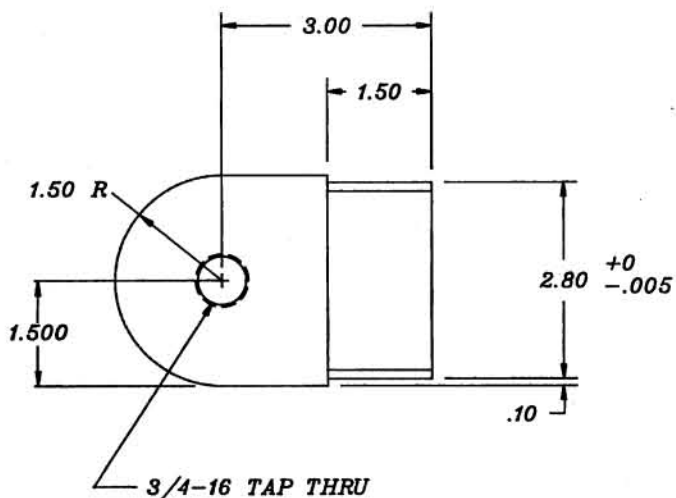
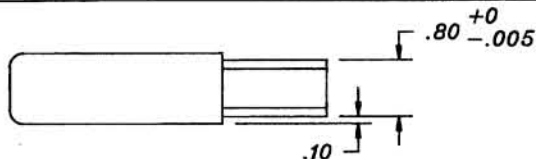

10 MAT'L. 1 X 3 BAR C.R. STEEL
2 REQ'D.

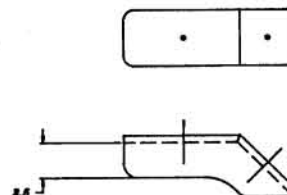
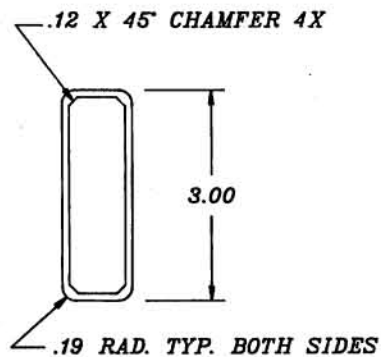

11 ARM PAD
2 REQ'D.

		APPROVALS		DATE	TITLE	
		HEWITT		8/90	M/F ARM ASS'Y.	
		HEWITT		8/90	SIZE: C	PSGM NO: 51300
TOLERANCES:		DIMENSIONS:		DRAWING NO: 51300		REV: A2
.004 .010 ANGLES & S/F		.004 .010 CONCENTRICITY & .005		SCALE:		SHEET: 4 OF:
.0006 .005 FLATNESS & .005		.0006 .005 ROUNDNESS & .005		SCALE: 51300		SHEET: 4 OF:
DO NOT SCALE DRAWING		SCALE:		51300		SHEET: 4 OF:

ARIEL LIFE SYSTEMS INC.
10110 SORRENTO VALLEY RD.
S.D., CA 92121 (619) 455-5952

3/4" RAD.
TYP. 4X

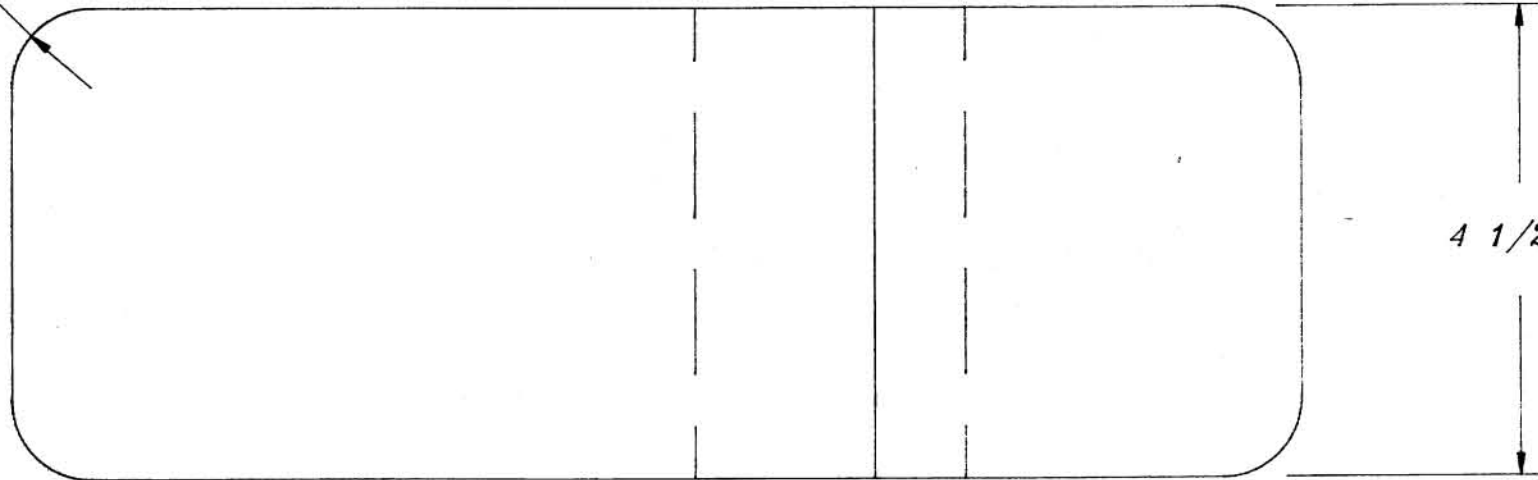

4 1/2"

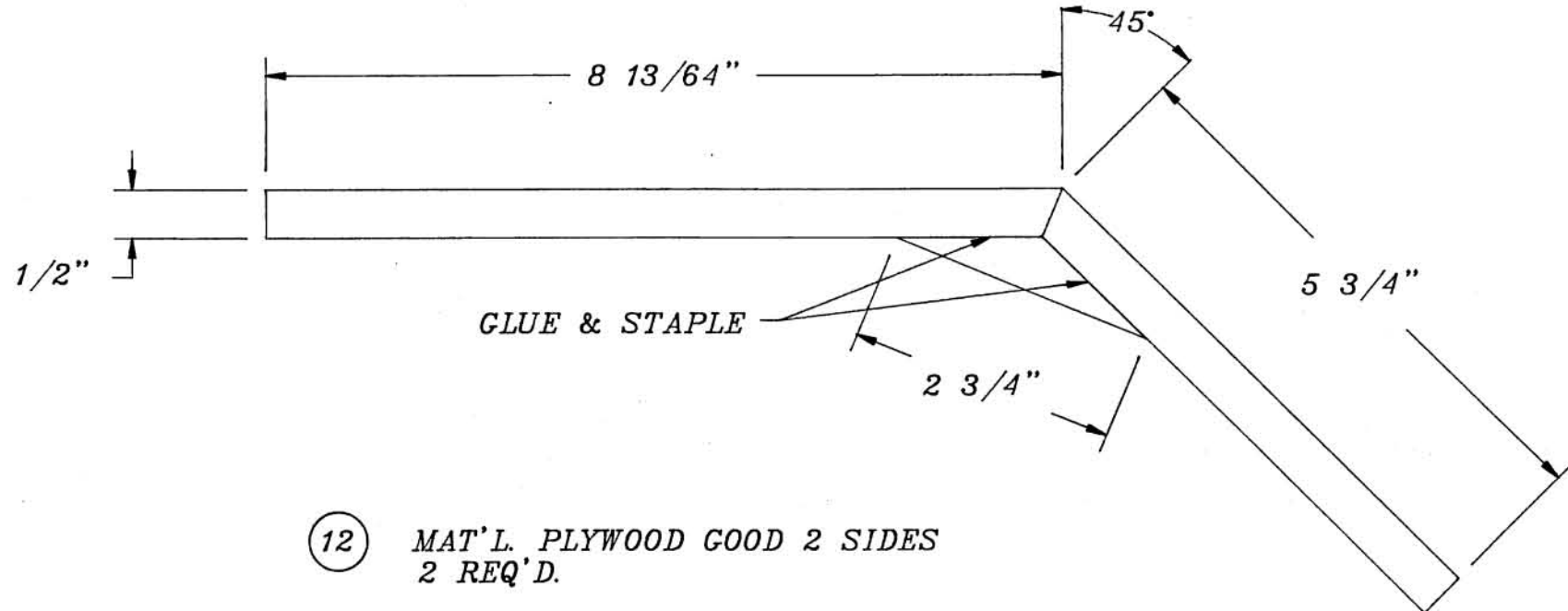

GLUE & STAPLE

(12) MAT'L. PLYWOOD GOOD 2 SIDES
2 REQ'D.

		ARIEL LIFE SYSTEMS INC. 1010 SORRENTO VALLEY RD. S.D.CA. 92121 (619) 466-6962	
APPROVALS	DATE	TITLE	
HEWITT	8/90	M/F ARM ASS'Y.	
HEWITT	8/90	SIZE	DRAWING NO.
		C	51300
DO NOT SCALE DRAWING		SCALE	SHEET 5 OF
<small>TOLERANCES: LINEAR .005 ANGLES ± 0.5° HOLE DIA .005 CONCENTRICITY ± .005 LOCUS .005 FLATNESS ± .005 CIRCULAR RUNOUT ± .005</small>		REV.	A2

REVISIONS			
REV	DESCRIPTION	DATE	APPROVED
A2	MOD AFTER PROTOTYPE BUILD	12/90	HEWITT

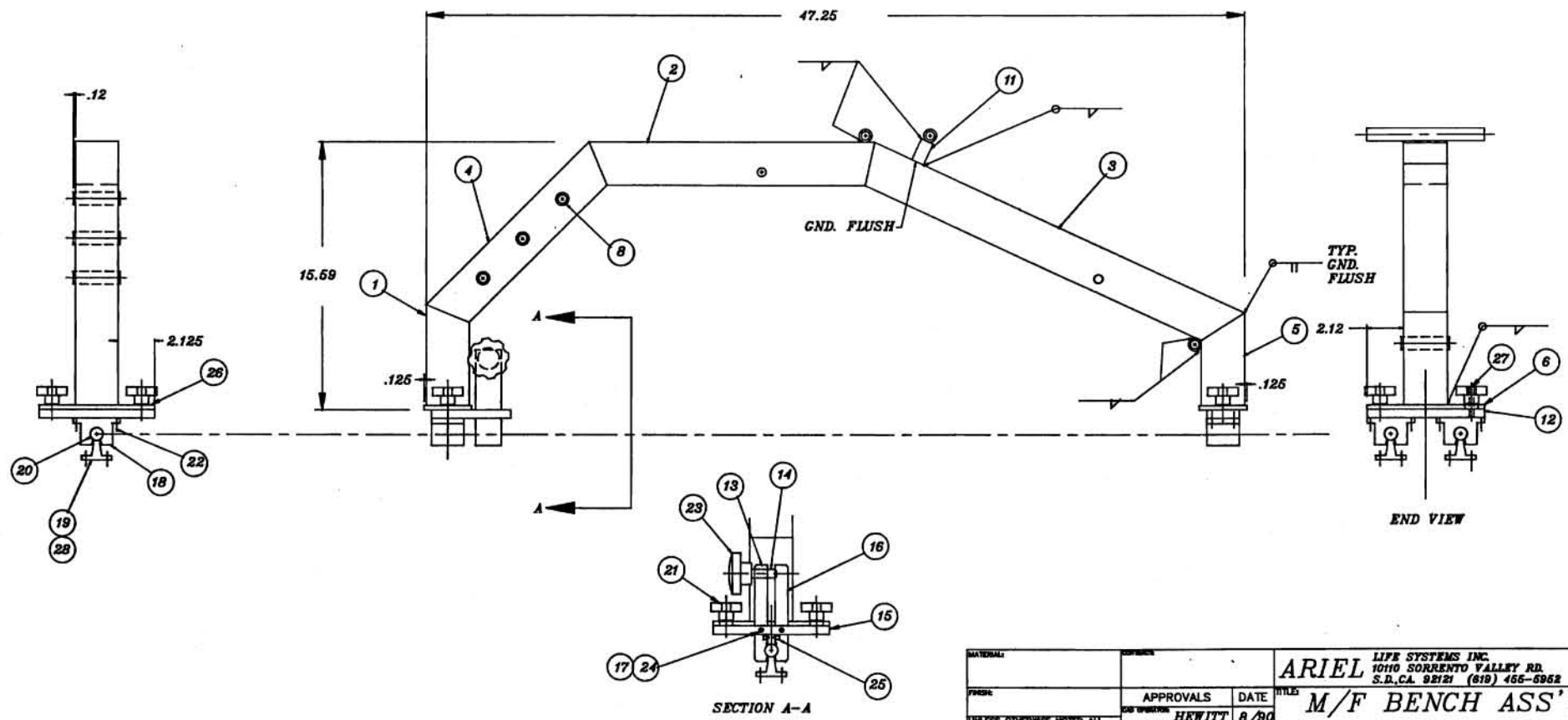
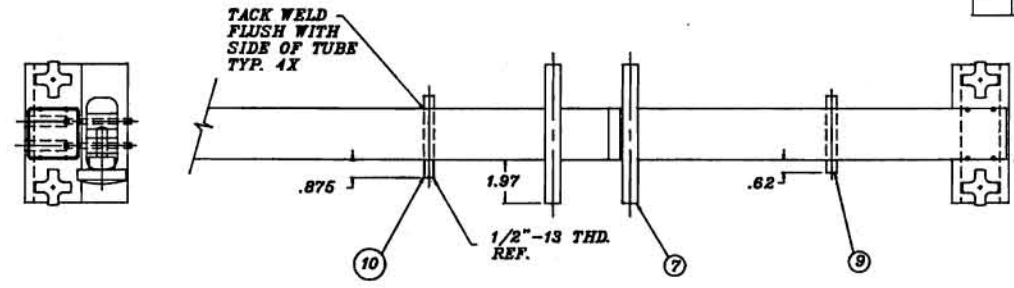

MATERIAL:		APPROVALS		DATE		TITLE	
UNLESS OTHERWISE NOTED ALL DIMENSIONS ARE IN INCHES		HEWITT		8/90		M/F BENCH ASS'Y.	
TOLERANCES:		HEWITT		8/90		DRAWING NO: 51400	
LINEAR		C		SIZE: 10"		REV: 42	
ANGLES & R/F		DO NOT SCALE DRAWING		SCALE: 10"		SHEET 1 OF 6	
HOLE							
CONCENTRICITY & POS							
FLATNESS & POS							
ROUNDNESS & POS							

ARIEL LIFE SYSTEMS INC.
10110 SORRENTO VALLEY RD.
S.D., CA. 92121 (619) 466-6952

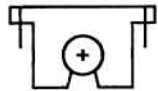

18 MAT'L THOMPSON OPEN
PILLOW BLOCK SPB-12-OPN
3 REQ'D.



22 MAT'L # 8-32 SOC. HD. CAP SCREW X .75 LG.
STEEL BLACK OXIDE
12 REQ'D.

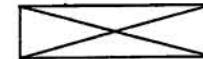

25 MAT'L COMP SPRING LEE # LC-028C-11
DIA .240 X .028 W.D. X 1 1/4" LG.
1 REQ'D.

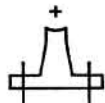

19 MAT'L THOMPSON SHAFT SUPPORT
SR-12-PD X 24" LG.
3 REQ'D.

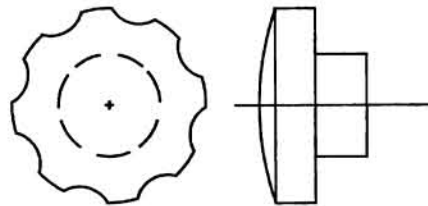

23 MAT'L KNOB CARR LANE # CL-88-PFK
1 REQ'D.

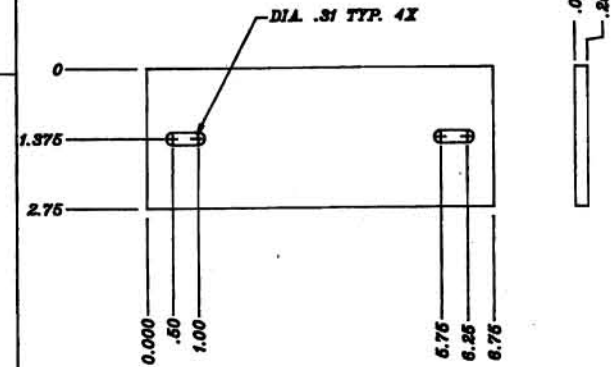

26 MAT'L .25" X 2.75 C.R. BAR
1 REQ'D.



20 MAT'L THOMPSON SHAFT .7500
CLASS L 60 CASE # QS 3/4" L 24 PD
3 REQ'D.

24 MAT'L SNAP RING DIA .25
4 REQ'D.

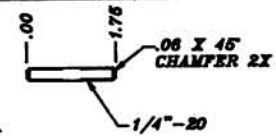

27 MAT'L 1/4"-20 THREADED ROD STEEL
4 REQ'D.

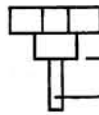

MODIFY ● ASS'Y.

21 MAT'L KNOB CARR LANE #CL-1-PPK-2T
4 REQ'D.

28 #10-32 SOC. HD. CAP SCREW X 1 1/4" LG. BLACK
12 REQ'D.

APPROVALS		DATE	TITLE	
HEWITT		8/90	M/F BENCH ASS'Y.	
HEWITT		8/90	SCALE	51400
DO NOT SCALE DRAWING		SCALE	51400C	SHEET 6 OF 12

ARIEL LIFE SYSTEMS INC.
10110 SORRENTO VALLEY RD.
S.D. CA 92121 (619) 465-6962

REVISIONS			
REV	DESCRIPTION	DATE	APPROVED
A1	REVISED METHOD OF MFG.	3/91	HEWITT

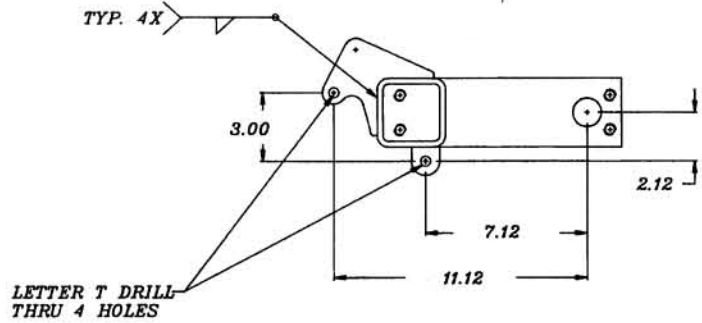
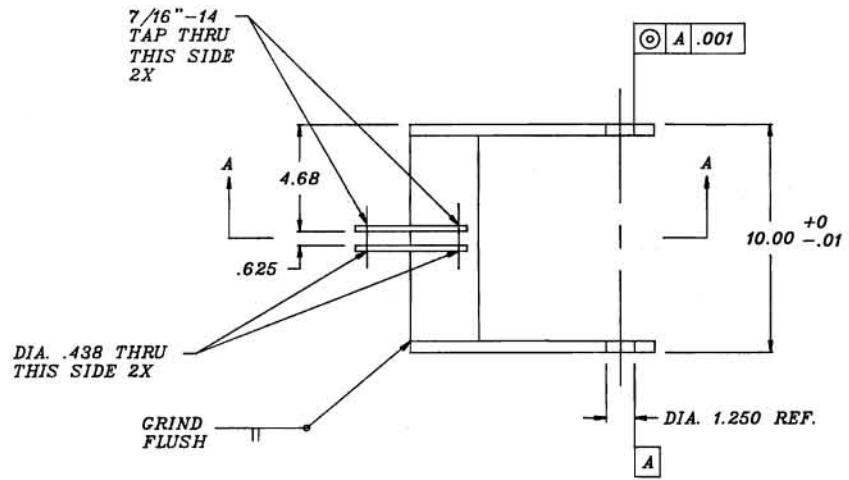

SECTION A-A

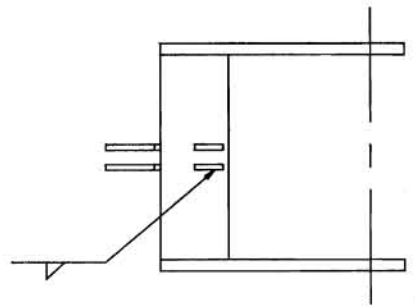

		ARIEL LIFE SYSTEMS INC. 10110 SORRENTO VALLEY RD. S.D., CA. 92121 (619) 456-5952	
APPROVALS	DATE	TITLE: M/F YOKE ASS'Y.	
HEWITT	11/90		
DESIGNER	DATE	SIZE: C	DRAWING NO.: 51500
HEWITT	11/90	SCALE:	SHEET: 1 OF 3
DO NOT SCALE DRAWING		FILE NO.: 51500	REV: A1

TOLERANCES
 LINEAR: .010 ANGLES: ± 0.1°
 HOLE: .005 CONCENTRICITY: ± .005
 JOG: .005 FLATNESS: ± .005
 SURFACE: .0005 ROUNDNESS: ± .005

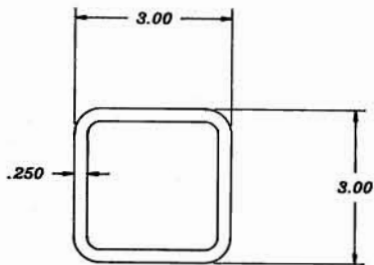
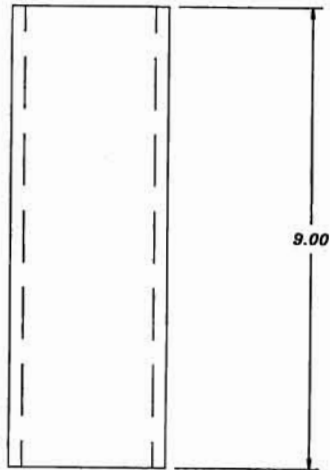

① MAT'L TUBE 3" SQ. X .250 WALL THK STEEL
1 REQ'D.

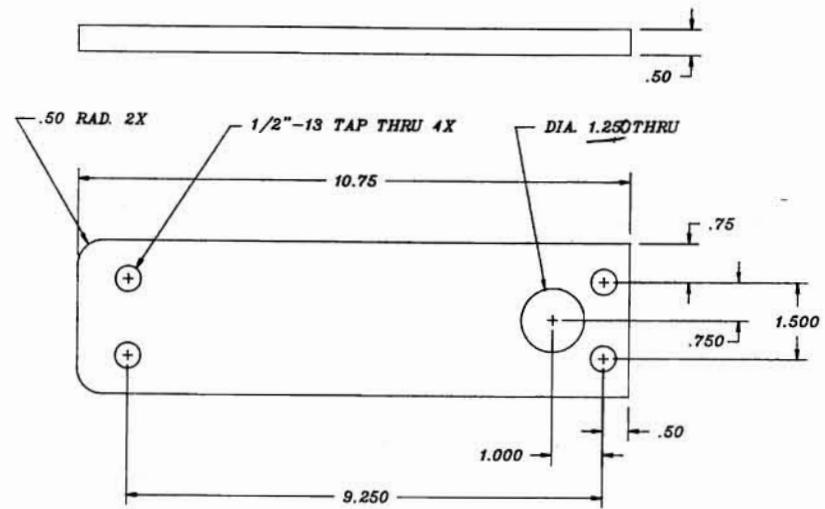

② MAT'L C.R. STEEL
2 REQ'D.

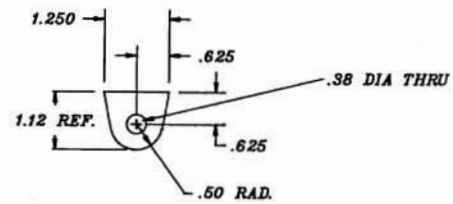

③ MAT'L 1/4" C.R. STEEL
2 REQ'D.

MATERIAL		FINISH		APPROVALS		DATE		TITLE	
				HEWITT		11/90		ARIEL LIFE SYSTEMS INC. 10110 SORRENTO VALLEY RD. S.B.C.A. 92121 (619) 456-6962	
UNLESS OTHERWISE NOTED ALL DIMENSIONS ARE IN INCHES								M/F YOKE ASS'Y.	
TOLERANCES		ANGLES		APPROVED		DATE		SIZE / PSCM NO.	
LINEAR .002		8 0.5°		HEWITT		11/90		C	
HOLE .002		CONCENTRICITY .005						DRAWING NO. 51500	
SLOPE .005		FLATNESS .005						REV. 1 A1	
ROUNDEDNESS .005								SCALE: 1" = 10"	
								PART NO. 51500 SHEET: 2 OF 1	

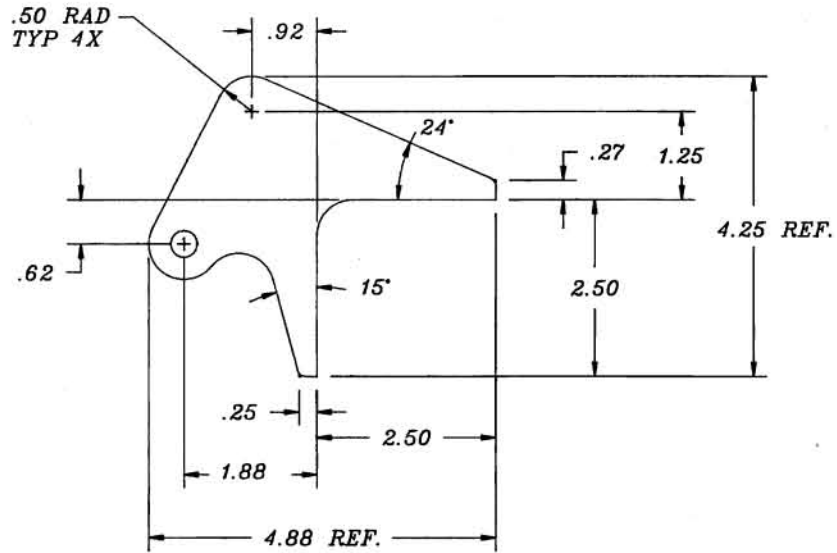

④ MAT'L 1/4" C.R. STEEL
2 REQ'D.

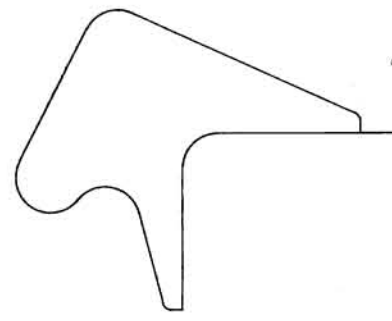

FLAME CUTTING PATTERN FOR ITEM 4

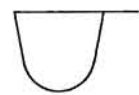

FLAME CUTTING PATTERN FOR ITEM 3

MATERIAL		DRAWING		ARIEL LIFE SYSTEMS INC. 10110 SORRENTO VALLEY RD. S.D.CA. 92121 (619) 455-5952	
PARTS		APPROVALS	DATE	TITLE	
UNLESS OTHERWISE NOTED ALL DIMENSIONS ARE IN INCHES		HEWITT	11/90	M/F YOKE ASS'Y.	
TOLERANCES		REV'S		SIZE	FORM NO.
LINEAR	ANGLES & 0.5°	C		DRAWING NO.	51500
LOSE .010	CONCENTRICITY & .005	HEWITT	11/90	SCALE	1" = 10"
LOSE .005	FLATNESS & .005	DO NOT SCALE DRAWING		ISS. FILE NO.	51500
LOSE .0005	ROUGHNESS & .005			SHEET	3 OF

REVISIONS			
REV	DESCRIPTION	DATE	APPROVED

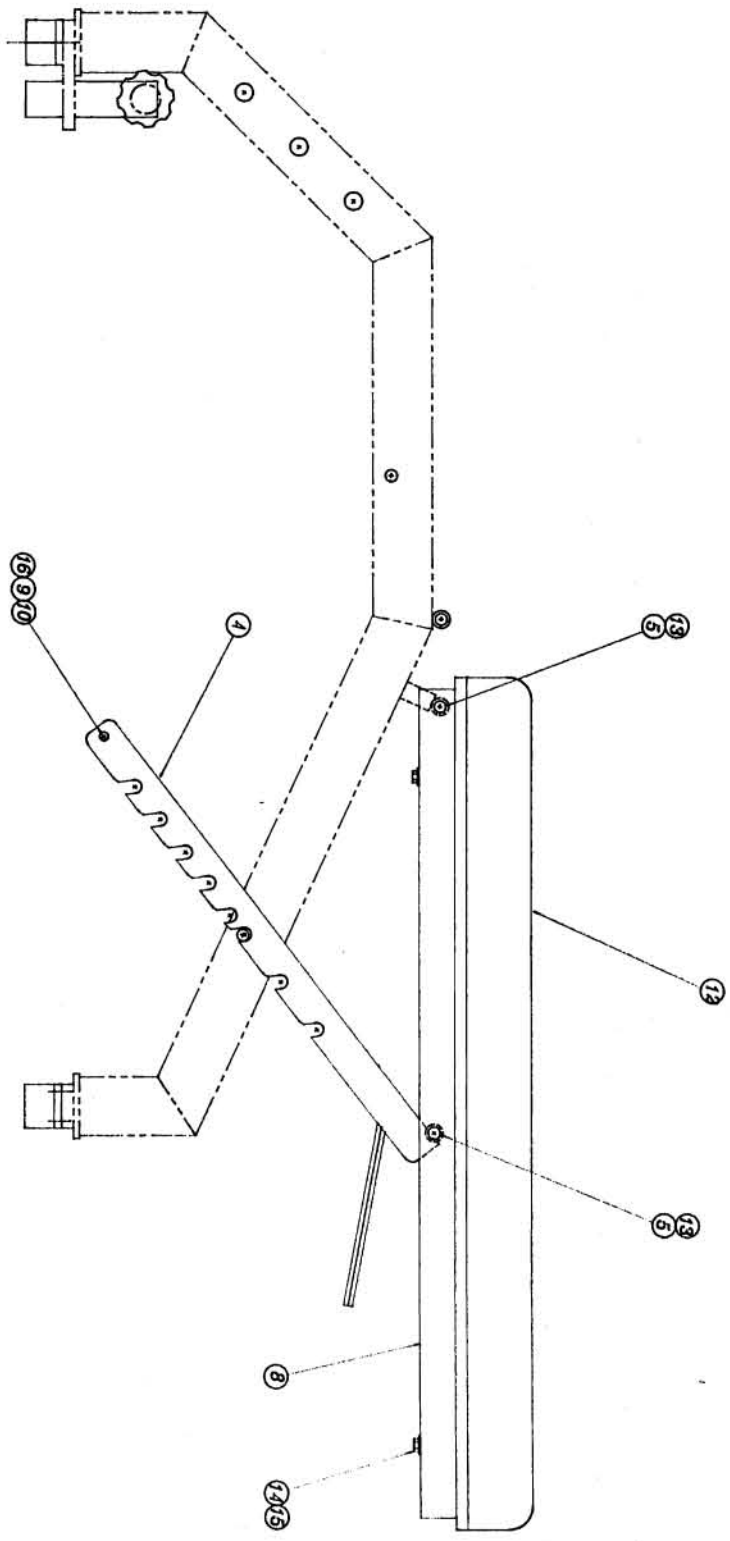

BILL OF MATERIALS	
NO.	DESCRIPTION
10	2 ALUMINUM ANGLE 3/8" X 3/8" X 1/8" CONTOUR PLATE
11	4 PLATE W/ASPER 1/4" GALV PLATE
12	4 1/4" X 1/4" X 1/8" BEEL DR. BOLT 1/2" DIA GALV PLATE
13	4 1/2" X 1/2" X 1/8" BEEL DR. BOLT 1/2" DIA GALV PLATE
14	4 1/2" X 1/2" X 1/8" BEEL DR. BOLT 1/2" DIA GALV PLATE
15	4 1/2" X 1/2" X 1/8" BEEL DR. BOLT 1/2" DIA GALV PLATE
16	4 1/2" X 1/2" X 1/8" BEEL DR. BOLT 1/2" DIA GALV PLATE
17	4 1/2" X 1/2" X 1/8" BEEL DR. BOLT 1/2" DIA GALV PLATE
18	4 1/2" X 1/2" X 1/8" BEEL DR. BOLT 1/2" DIA GALV PLATE
19	4 1/2" X 1/2" X 1/8" BEEL DR. BOLT 1/2" DIA GALV PLATE
20	4 1/2" X 1/2" X 1/8" BEEL DR. BOLT 1/2" DIA GALV PLATE
21	4 1/2" X 1/2" X 1/8" BEEL DR. BOLT 1/2" DIA GALV PLATE
22	4 1/2" X 1/2" X 1/8" BEEL DR. BOLT 1/2" DIA GALV PLATE
23	4 1/2" X 1/2" X 1/8" BEEL DR. BOLT 1/2" DIA GALV PLATE
24	4 1/2" X 1/2" X 1/8" BEEL DR. BOLT 1/2" DIA GALV PLATE
25	4 1/2" X 1/2" X 1/8" BEEL DR. BOLT 1/2" DIA GALV PLATE
26	4 1/2" X 1/2" X 1/8" BEEL DR. BOLT 1/2" DIA GALV PLATE
27	4 1/2" X 1/2" X 1/8" BEEL DR. BOLT 1/2" DIA GALV PLATE
28	4 1/2" X 1/2" X 1/8" BEEL DR. BOLT 1/2" DIA GALV PLATE
29	4 1/2" X 1/2" X 1/8" BEEL DR. BOLT 1/2" DIA GALV PLATE
30	4 1/2" X 1/2" X 1/8" BEEL DR. BOLT 1/2" DIA GALV PLATE
31	4 1/2" X 1/2" X 1/8" BEEL DR. BOLT 1/2" DIA GALV PLATE
32	4 1/2" X 1/2" X 1/8" BEEL DR. BOLT 1/2" DIA GALV PLATE
33	4 1/2" X 1/2" X 1/8" BEEL DR. BOLT 1/2" DIA GALV PLATE
34	4 1/2" X 1/2" X 1/8" BEEL DR. BOLT 1/2" DIA GALV PLATE
35	4 1/2" X 1/2" X 1/8" BEEL DR. BOLT 1/2" DIA GALV PLATE
36	4 1/2" X 1/2" X 1/8" BEEL DR. BOLT 1/2" DIA GALV PLATE
37	4 1/2" X 1/2" X 1/8" BEEL DR. BOLT 1/2" DIA GALV PLATE
38	4 1/2" X 1/2" X 1/8" BEEL DR. BOLT 1/2" DIA GALV PLATE
39	4 1/2" X 1/2" X 1/8" BEEL DR. BOLT 1/2" DIA GALV PLATE
40	4 1/2" X 1/2" X 1/8" BEEL DR. BOLT 1/2" DIA GALV PLATE
41	4 1/2" X 1/2" X 1/8" BEEL DR. BOLT 1/2" DIA GALV PLATE
42	4 1/2" X 1/2" X 1/8" BEEL DR. BOLT 1/2" DIA GALV PLATE
43	4 1/2" X 1/2" X 1/8" BEEL DR. BOLT 1/2" DIA GALV PLATE
44	4 1/2" X 1/2" X 1/8" BEEL DR. BOLT 1/2" DIA GALV PLATE
45	4 1/2" X 1/2" X 1/8" BEEL DR. BOLT 1/2" DIA GALV PLATE
46	4 1/2" X 1/2" X 1/8" BEEL DR. BOLT 1/2" DIA GALV PLATE
47	4 1/2" X 1/2" X 1/8" BEEL DR. BOLT 1/2" DIA GALV PLATE
48	4 1/2" X 1/2" X 1/8" BEEL DR. BOLT 1/2" DIA GALV PLATE
49	4 1/2" X 1/2" X 1/8" BEEL DR. BOLT 1/2" DIA GALV PLATE
50	4 1/2" X 1/2" X 1/8" BEEL DR. BOLT 1/2" DIA GALV PLATE

APPROVALS		DATE	TITLE
APPROVED		8/31	ARIEL, 1010 SORRENTO VALLEY RD. S.W.CK. 287TH. (615) 466-8863
DRAWN BY		DATE	SCALE
DRAWN		8/31	C
CHECKED BY		DATE	SCALE
CHECKED		8/31	C
DESIGNED BY		DATE	SCALE
DESIGNED		8/31	C
MATERIALS		DATE	SCALE
MATERIALS		8/31	C
FINISH		DATE	SCALE
FINISH		8/31	C
UNLESS OTHERWISE NOTED ALL DIMENSIONS ARE IN INCHES			
TOLERANCES ARE AS FOLLOWS			
FRACTIONS .0005 .001 .002 .005 .010 .015 .030 .060 .125 .250 .500 .750 1.000			
DECIMALS .0005 .001 .002 .005 .010 .015 .030 .060 .125 .250 .500 .750 1.000			
ANGLES .0005 .001 .002 .005 .010 .015 .030 .060 .125 .250 .500 .750 1.000			
HOLE DIA .0005 .001 .002 .005 .010 .015 .030 .060 .125 .250 .500 .750 1.000			
TAP DIA .0005 .001 .002 .005 .010 .015 .030 .060 .125 .250 .500 .750 1.000			
THREADS .0005 .001 .002 .005 .010 .015 .030 .060 .125 .250 .500 .750 1.000			
DO NOT SCALE DRAWING SCALES			

ARIEL, 1010 SORRENTO VALLEY RD.
S.W.CK. 287TH. (615) 466-8863

M/F BACK ASSY.
DRAWING NO. 51600
REV. 1 OF 5

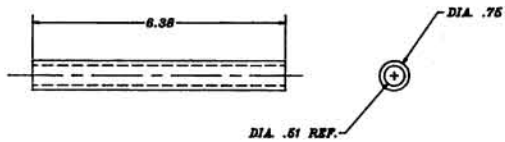

② MAT'L. TUBE, 3/4" OD. X .120 WALL DOM STEEL
1 REQ'D.

REVISIONS			
REV	DESCRIPTION	DATE	APPROVED

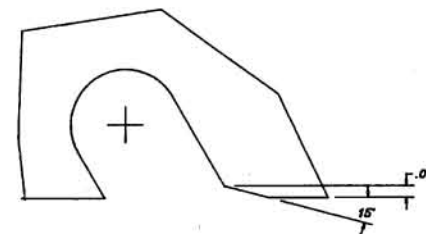
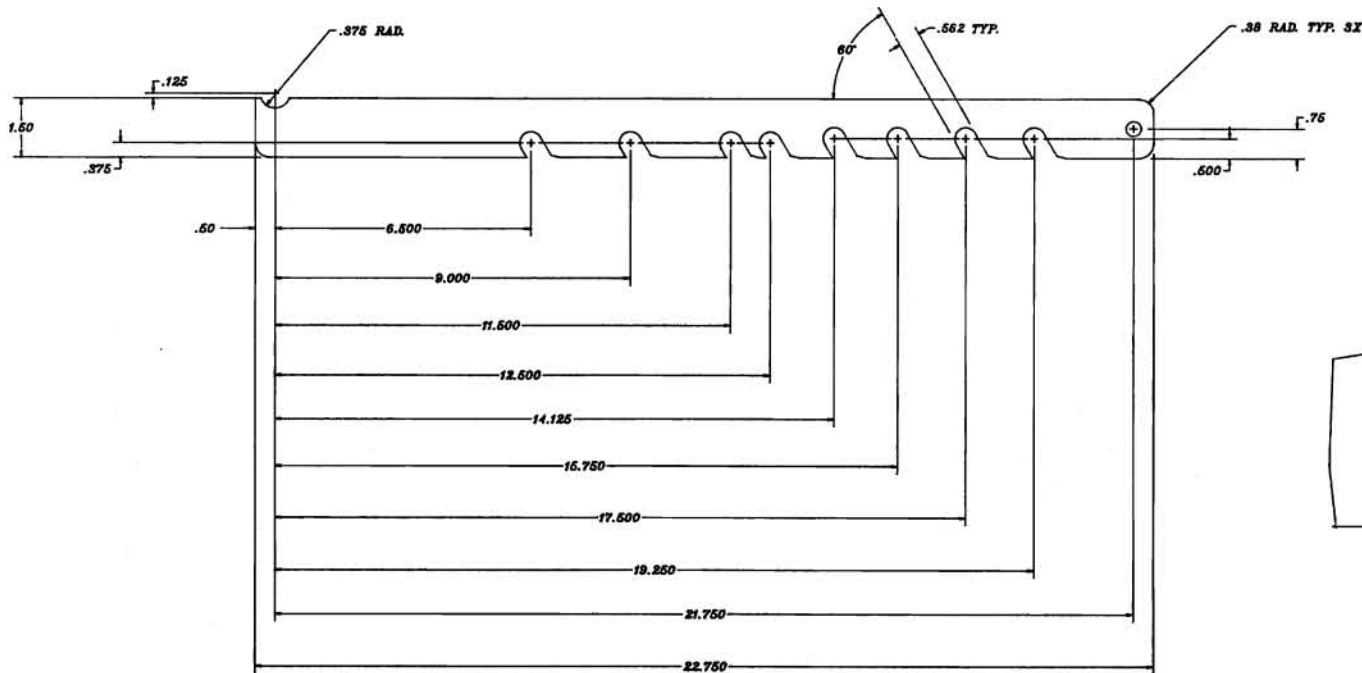

NOTCH DETAIL
TYP. 3X

① MAT'L. C.R.S. FLAT BAR 1/4" X 1 1/2"
2 REQ'D.

APPROVALS		DATE	TITLE	
HEWITT		8/91	M/F BACK ASSY.	
DESIGNER		DRIVER	SIZE: C	SCM NO.: 51600
TOLERANCES:		ANGLES & D.P.		DRAWING NO.: 51600
LINEAR .005		CONCENTRICITY & .005		REV: A
HOLE .005		FLATNESS & .005		
HOLE .005		ROUNDEDNESS & .005		
DO NOT SCALE DRAWING		SCALE:	51600	SHEET: 2 OF:

ARIEL LIFE SYSTEMS INC.
10110 SORRENTO VALLEY RD.
S.D., CA. 92121 (619) 455-6962

REVISIONS			
REV	DESCRIPTION	DATE	APPROVED

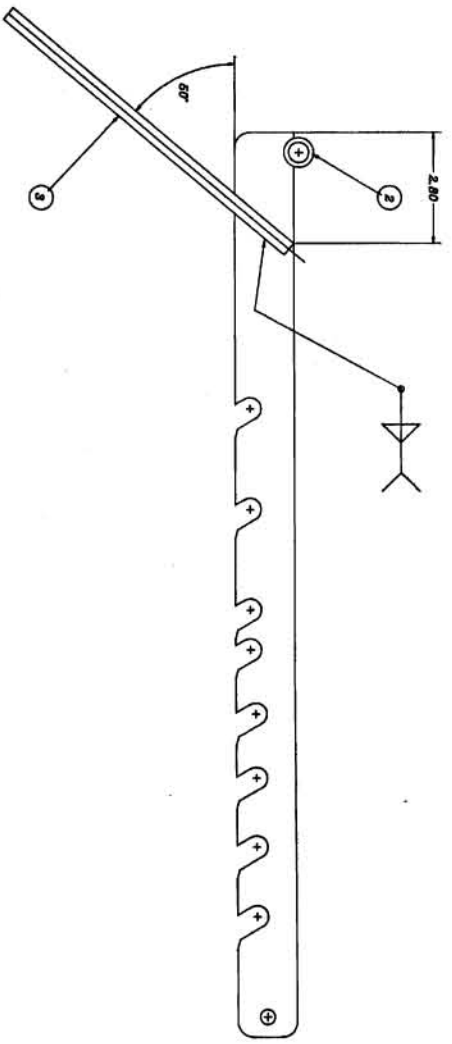
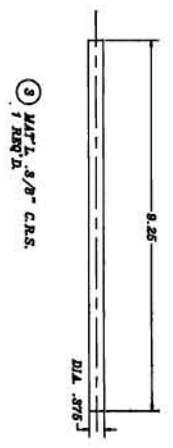
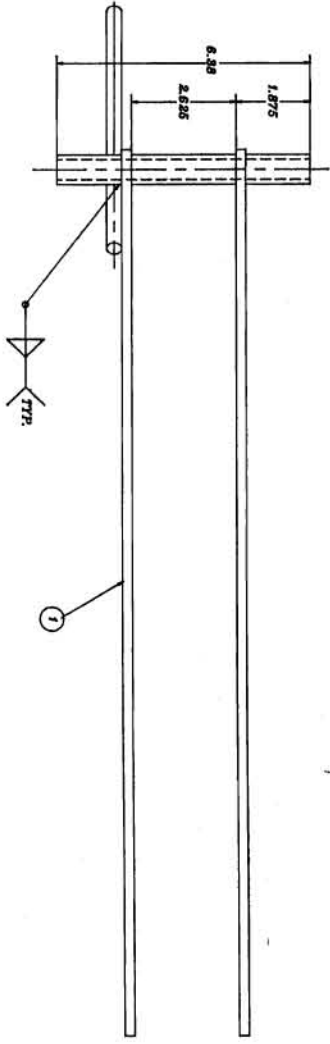

4 BACK ADJ. BRACKET ASSEMBLY
PLATE, COPPER NICKEL CHROME
1 REV'D.

APPROVALS HEWITT 8/91		DATE 8/91	
TITLE M/F BACK ASSY.		SCALE 51600	
DRAWING NO. 51600		SHEETS 3 OF 3	

ARIEL
 1010 SORRENTO VALLEY RD.
 S.D.C. 92121 (619) 455-9962
 LIME SYSTEMS INC.

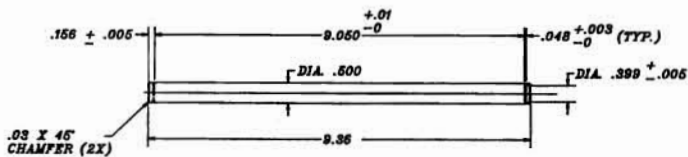

⑥ MAT'L. 1/2" DIA. C.R. STEEL
2 REQ'D.
BLACK OXIDE/OIL

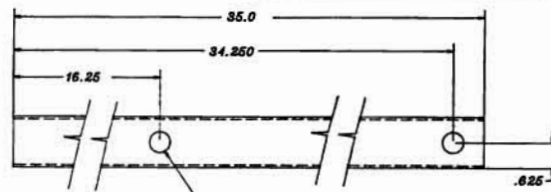

DIA. .515 THRU BOTH WALLS
TYP. 2X
MATCH DRILL 2 PIECES



⑦ MAT'L. TUBE 1.25 SQ. X .085 WALL KW STEEL
2 REQ'D.

REVISIONS			
REV	DESCRIPTION	DATE	APPROVED

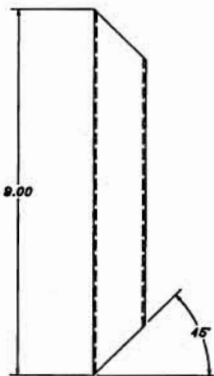

⑤ MAT'L. TUBE 1.25 SQ. X .085 WALL KW STEEL
1 REQ'D.

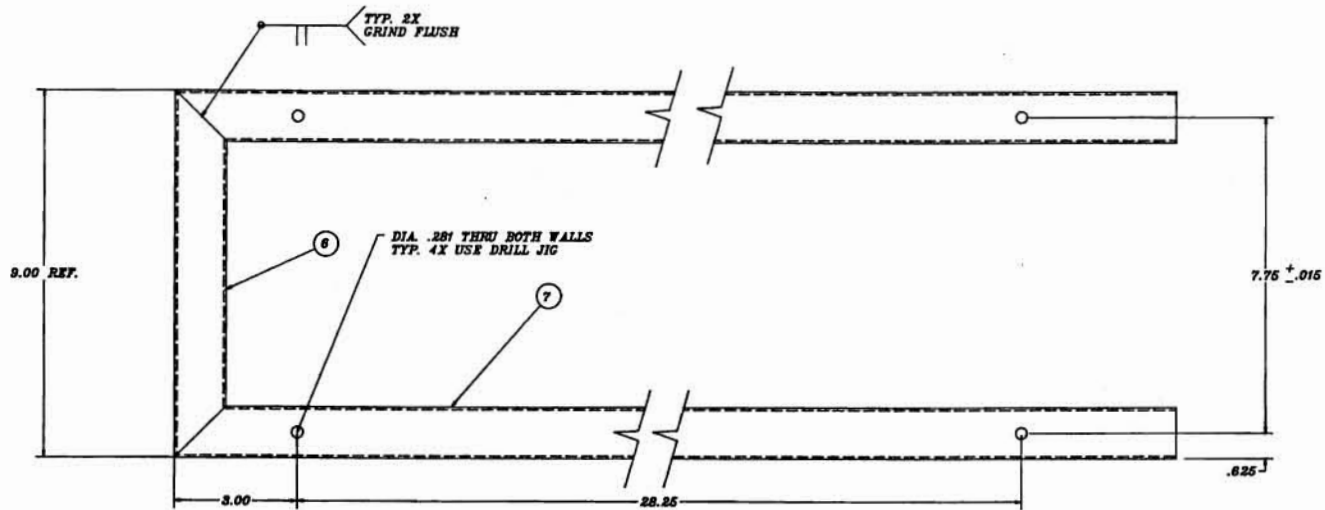

TYP. 2X
GRIND FLUSH

DIA. .281 THRU BOTH WALLS
TYP. 4X USE DRILL JIG

ALIGN HOLES WITH 1/2" ROD
PRIOR TO WELDING 2X

⑧ SEAT FRAME
1 REQ'D.
POWDER COAT WRINKLE BLACK

UNLESS OTHERWISE NOTED ALL DIMENSIONS ARE IN INCHES		APPROVALS		DATE	ARIEL LIFE SYSTEMS INC. 10110 SORRENTO VALLEY RD. S.D., CA. 92121 (619) 466-6962 TITLE: M/F BACK ASS'Y.	
DESIGNER	HEWITT	DATE	8/91	SIZE	FORM NO.	DRAWING NO.
LINEAR	ANGLES ± 0.1°	APPROVER		C		51600
±0.04 ±0.005	CONCENTRICITY ± .005	DO NOT SCALE DRAWING	SCALE:	REV.	51600	A
±0.004 ±0.005	FLATNESS ± .005				SHEET: 4	OF:

51600

REVISIONS			
REV	DESCRIPTION	DATE	APPROVED

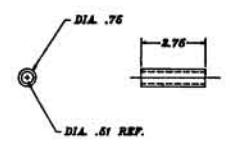

⑨ MAT'L. TUBE, 3/4" OD. X .120 WALL DOM STEEL
1 REQ'D.
PLAYS, COPPER NICKLE CHROME

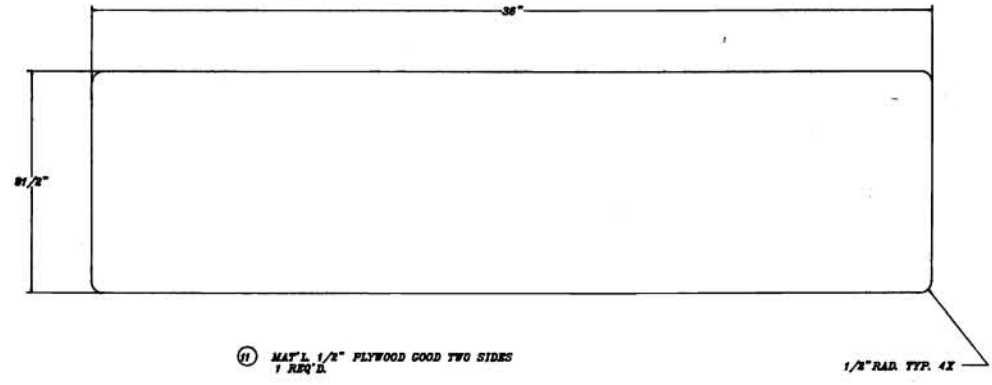

⑪ MAT'L. 1/2" PLYWOOD GOOD TWO SIDES
1 REQ'D.

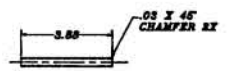

⑩ MAT'L. 3/8"-10 ALLTHREAD STEEL CAP. PLAYS OR EQ.
1 REQ'D.

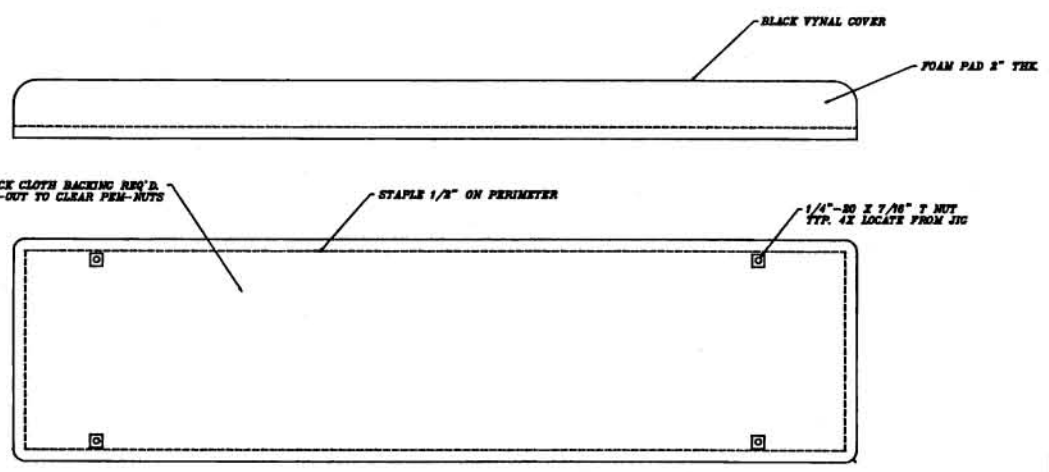

⑫ BACK CUSHION ASSEMBLY
1 REQ'D.

APPROVALS		DATE	FILE:	
HEWITT		8/91	M/F BACK ASSY.	
DESIGNER		SIZE: C	SCM NO.:	DRAWING NO. 51600
TOLERANCES: LINEAR .002 HOLE .002 ANGLES & 0.1° DIMENSIONS & .005 FLATNESS & .005 ROUNDNESS & .005		SCALE:	REV: A	REV: A
DO NOT SCALE DRAWING		SCALE:	SHEET: 5	OF: 5

ARIEL LIFE SYSTEMS INC.
1010 SORRENTO VALLEY RD.
S.D., CA. 92121 (619) 465-5952

REVISIONS			
REV	DESCRIPTION	DATE	APPROVED

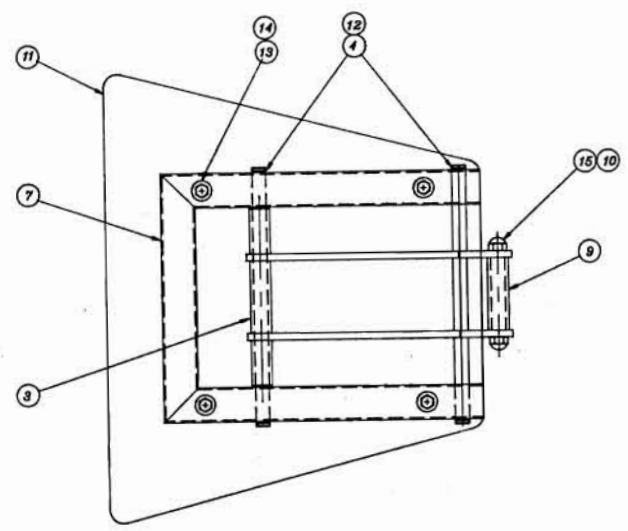
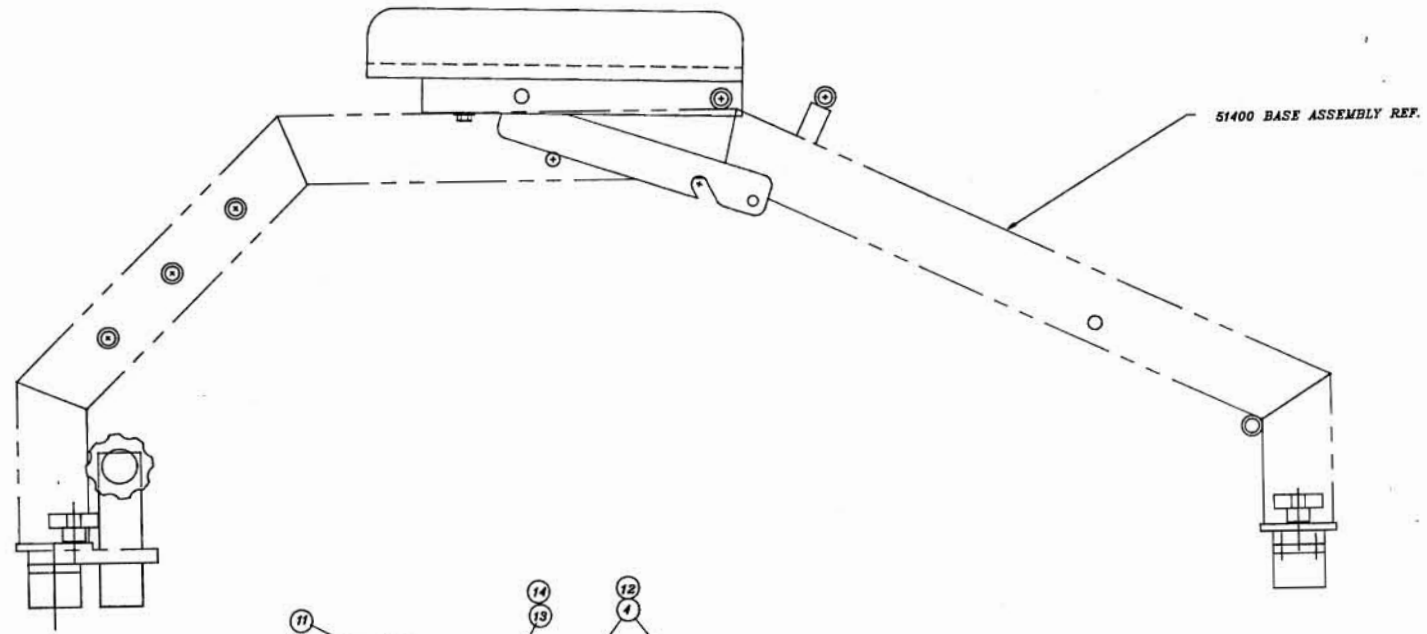

ITEM NO.	QTY	DESCRIPTION
15	2	ACORN NUT 3/8"-16 CHROME PLATE
14	4	FLAT WASHER 1/4" CAD. PLATE
13	4	1/4"-20 HEX. HD. BOLT X 2" LG. CAD. PLATE
12	4	E - RING FOR 1/2" SHAFT BERG # 9Q29-60 OR EQUAL BLACK OXID

UNLESS OTHERWISE NOTED ALL DIMENSIONS ARE IN INCHES

TOLERANCES:
 LINEAR: .004 .010
 ANGLES: ± 0.2°
 CONCENTRICITY: ± .005
 FLATNESS: ± .005
 ROUNDNESS: ± .005

APPROVALS: HEWITT DATE: 7/91

SCALE: DO NOT SCALE DRAWING

SIZE: C

DRIVING NO.: 51700

REV: A

SHEET: 1 OF 5

ARIEL
 LIFE SYSTEMS INC.
 10110 SORRENTO VALLEY RD.
 S.D.CA. 92121 (619) 455-5952

TITLE: M/F SEAT ASS'Y.

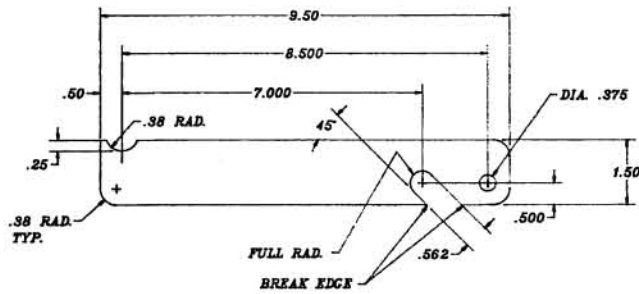

① MAT'L. 1/4" THK X 1.5" C.R. BAR
2 REQ'D.

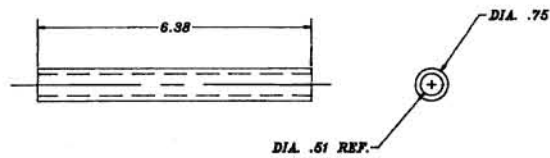

② MAT'L. TUBE, 3/4" OD. X .120 WALL DOM STEEL
1 REQ'D.

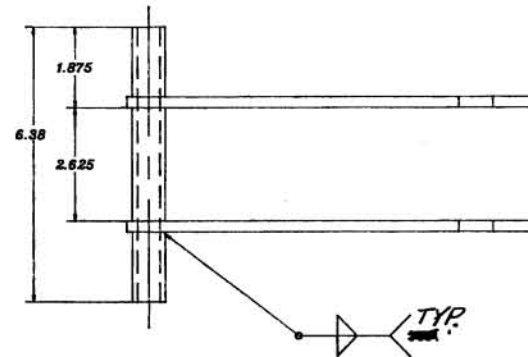
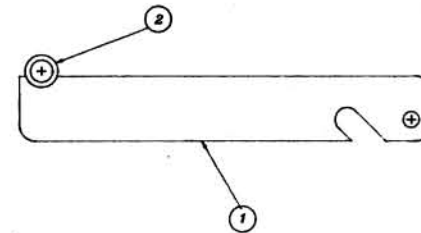

③ SEAT ADJ. BRACKET ASSEMBLY
PLATE, COPPER NICKLE CHROME
1 REQ'D.

APPROVALS		DATE	TITLE	
HEWITT		7/91	M/F SEAT ASS'Y.	
DESIGNED BY		CHECKED BY	STEEL FORM NO.	DRAWING NO.
DRAWN BY		APPROVED BY	C	51700
DATE		SCALE	REV.	SHEET
7/91		1:1	51700	2 OF 2

ARIEL LIFE SYSTEMS INC.
10110 SORRENTO VALLEY RD.
S.D., CA. 92121 (619) 455-6952

ALL DIMENSIONS UNLESS OTHERWISE SPECIFIED ARE IN INCHES.
DIMENSIONS ARE TO CENTER UNLESS OTHERWISE SPECIFIED.
DIMENSIONS ARE TO CENTER UNLESS OTHERWISE SPECIFIED.
DIMENSIONS ARE TO CENTER UNLESS OTHERWISE SPECIFIED.

NOT SCALE DRAWING SCALE

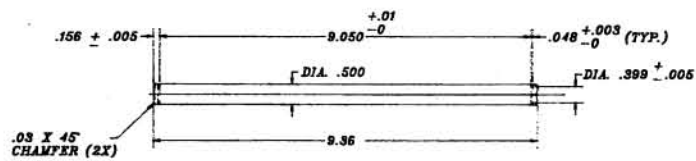

④ MAT'L 1/2" DIA. C.R. STEEL
2 REQ'D.
BLACK OXIDE/OIL

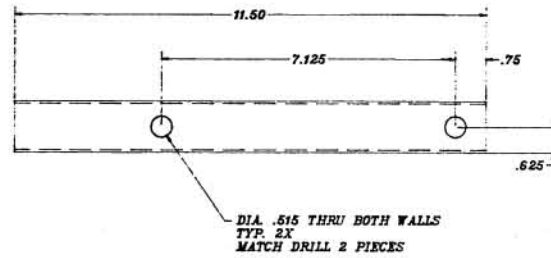

⑥ MAT'L TUBE 1.25 SQ. X .065 WALL EW STEEL
2 REQ'D.

REVISIONS			
REV.	DESCRIPTION	DATE	APPROVED

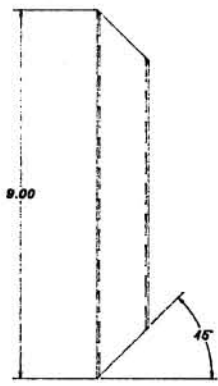

⑤ MAT'L TUBE 1.25 SQ. X .065 WALL EW STEEL
1 REQ'D.

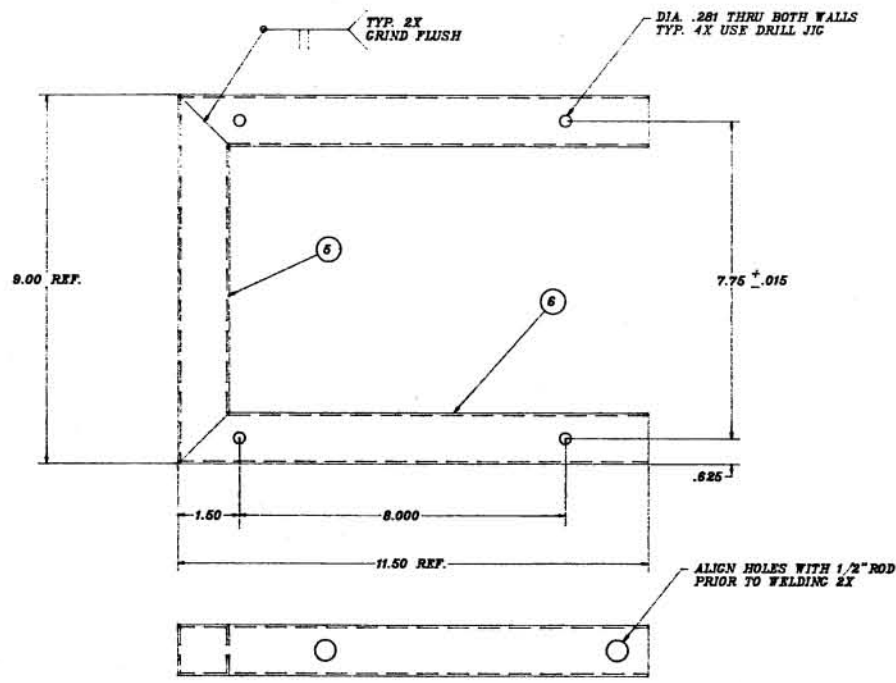

⑦ SEAT FRAME
1 REQ'D.
POWDER COAT WRINKLE BLACK

APPROVALS		DATE	TITLE
HEWITT		7/91	M/F SEAT ASS'Y.
UNLESS OTHERWISE NOTED ALL DIMENSIONS ARE IN INCHES		SIZE	FORM NO.
TOLERANCES:		ANGLES & R/F	DRAWING NO.
LINEAR	±.010	CONCENTRICITY ±.005	51700
HOLES	±.005	FLATNESS ±.005	REV. A
ROUNDED	±.005	ROUNDNESS ±.005	
DO NOT SCALE DRAWING SCALE:		QTY FILED:	51700
		SHEET:	3 OF 3

ARIEL LIFE SYSTEMS INC.
10110 SORRENTO VALLEY RD.
S.D.C.A. 92121 (619) 455-5952

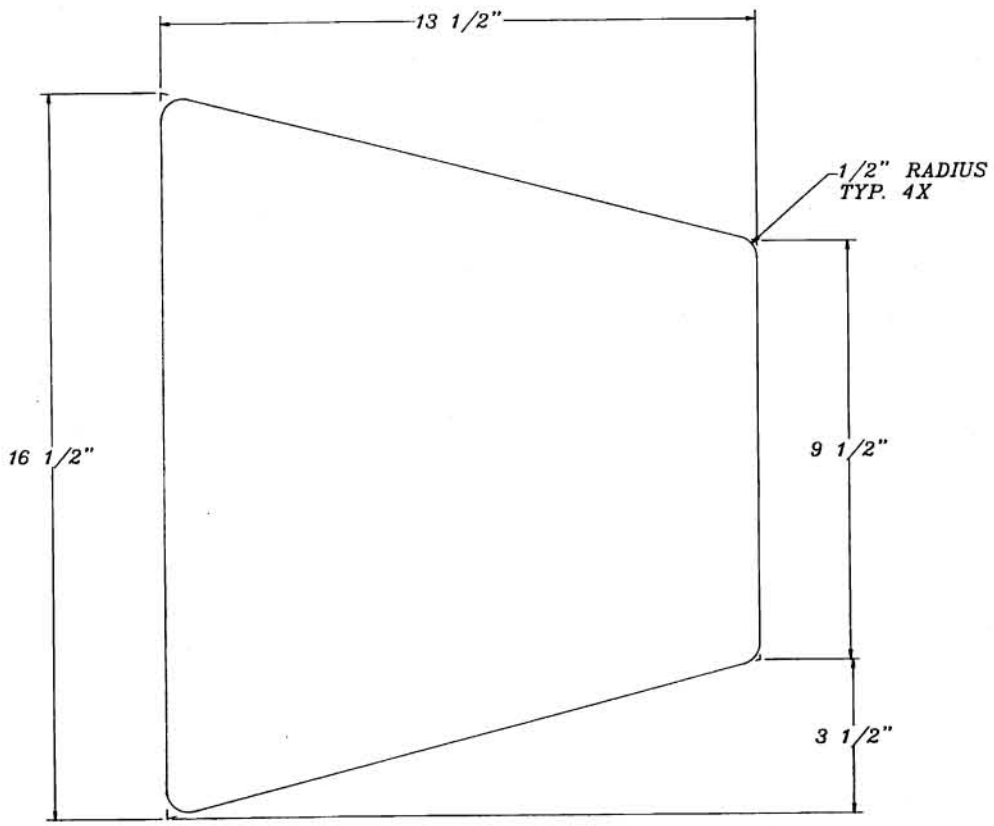

⑧ MAT'L. PLYWOOD GOOD 2 SIDES
1 REQ'D.

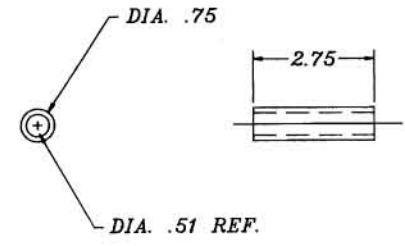

⑨ MAT'L. TUBE, 3/4" O.D. X .120 WALL DOM STEEL
1 REQ'D.
PLATE, COPPER NICKLE CHROME

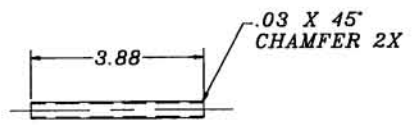

⑩ MAT'L. 3/8"-16 ALLTHREAD STEEL CAD. PLATE OR EQ.
1 REQ'D.

UNLESS OTHERWISE NOTED ALL DIMENSIONS ARE IN INCHES		APPROVALS		DATE	TITLE	
TOLERANCES:		HEWITT		7/91	ARIEL LIFE SYSTEMS INC. 10110 SORRENTO VALLEY RD. S.D., CA. 92121 (619) 455-5952	
LINEAR:	ANGLES: ± 0.5°	C		SIZE: FSCM NO.:	DRAWING NO.:	REV.:
.004	.005	DO NOT SCALE DRAWING		SCALE:	51700	A
.0008	.005	SCALE:		FILE NO.:	51700	SHEET: 4 OF:
.0008	.005	SCALE:		FILE NO.:	51700	SHEET: 4 OF:

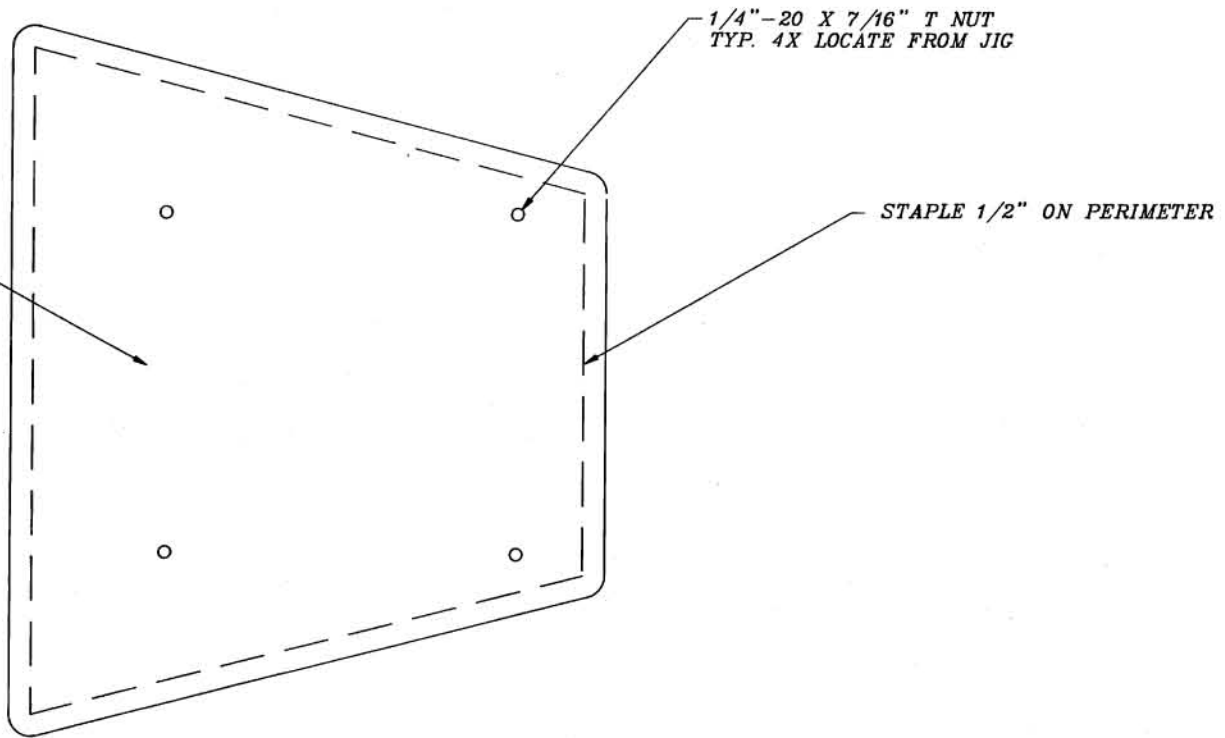
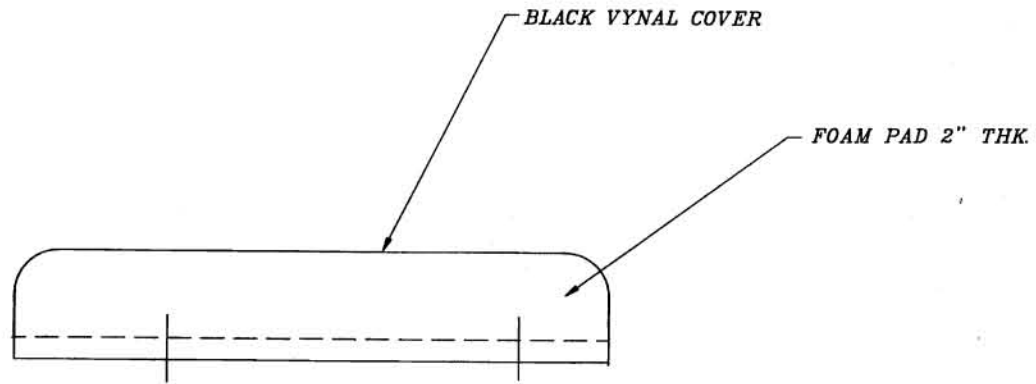

⑪ SEAT CUSHION ASSEMBLY
1 REQ'D.

APPROVALS		DATE	TITLE	
HEWITT		7/91	M/F SEAT ASS'Y.	
UNLESS OTHERWISE NOTED ALL DIMENSIONS ARE IN INCHES		SIZE: C	SCM NO.:	DRAWING NO.:
TOLERANCES: LINEAR: .010 ANGLES & SLIP: .005 HOLE: .005 CONCENTRICITY: .005 SLOPE: .005 FLATNESS: .005 SURFACE: .005 ROUGHNESS: .005		WORKS:	FILE NO.:	51700
DO NOT SCALE DRAWING		SCALE:	SHEET: 5	OF:

ARIEL LIFE SYSTEMS INC.
10110 SORRENTO VALLEY RD.
S.D.C.A. 92121 (619) 456-5962

REV: A

REVISIONS			
REV	DESCRIPTION	DATE	APPROVED
A2	MOD. AFTER PROTO-TYPE BUILD	12/90	HEWITT

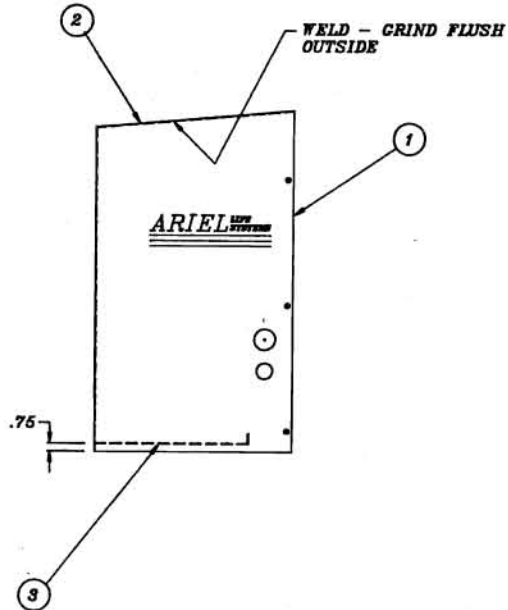
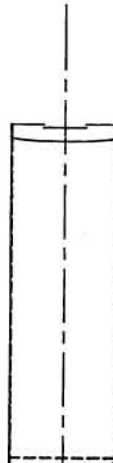
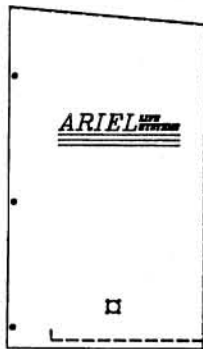
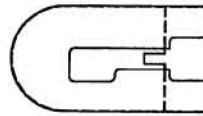

TACK WELD

WELD - GRIND FLUSH OUTSIDE

MATERIAL:		FINISH:		ARIEL LIFE SYSTEMS INC. 10110 SORRENTO VALLEY RD. S.D., CA. 92121 (619) 455-6952	
UNLESS OTHERWISE NOTED ALL DIMENSIONS ARE IN INCHES TOLERANCES: DIMS: .005 ANGLES & R OF .005 HOLE DIA: .005 CONCENTRICITY & .005 FLATNESS & .005 SURFACE: .0005 SQUARENESS & .005		APPROVALS HEWITT	DATE 8/90	TITLE M/F SHROUD	DRAWING NO: 51800
DO NOT SCALE DRAWING		SCALE: $\frac{1}{10}$ "	REV: A2	SHEET 1 OF 4	

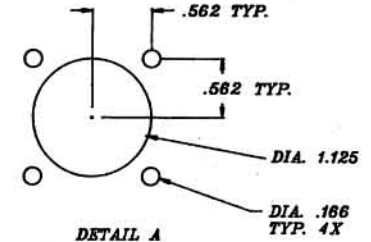
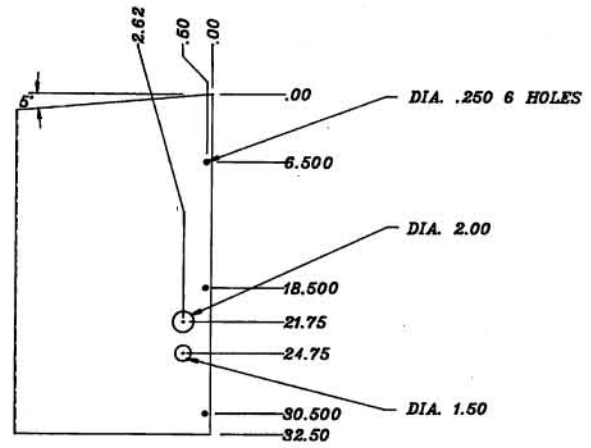
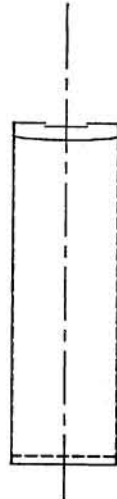
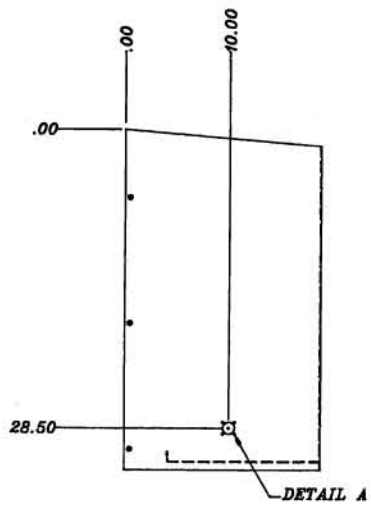

① MAT'L 18 GA. (.0478) STEEL

MATERIAL:		SERVICE:		ARIEL LIFE SYSTEMS INC. 10110 SORRENTO VALLEY RD. S.D.C.A. 92121 (619) 455-6962	
FINISH:	APPROVALS:	DATE:	TITLE:		
UNLESS OTHERWISE NOTED ALL DIMENSIONS ARE IN INCHES	HEWITT	8/90	M/F SHROUD		
TOLERANCES:	HEWITT	8/90	SIZE:	FORM NO.:	DRAWING NO.:
LENGTH .005			C		51800
ANGLE & C/P .005					REV.:
EDGE .005					A2
FLATNESS .005					
ROUNDNESS .005					
DO NOT SCALE DRAWING			SCALE: 1"=10"	FILE NO. 51800A	SHEET: 2 OF:

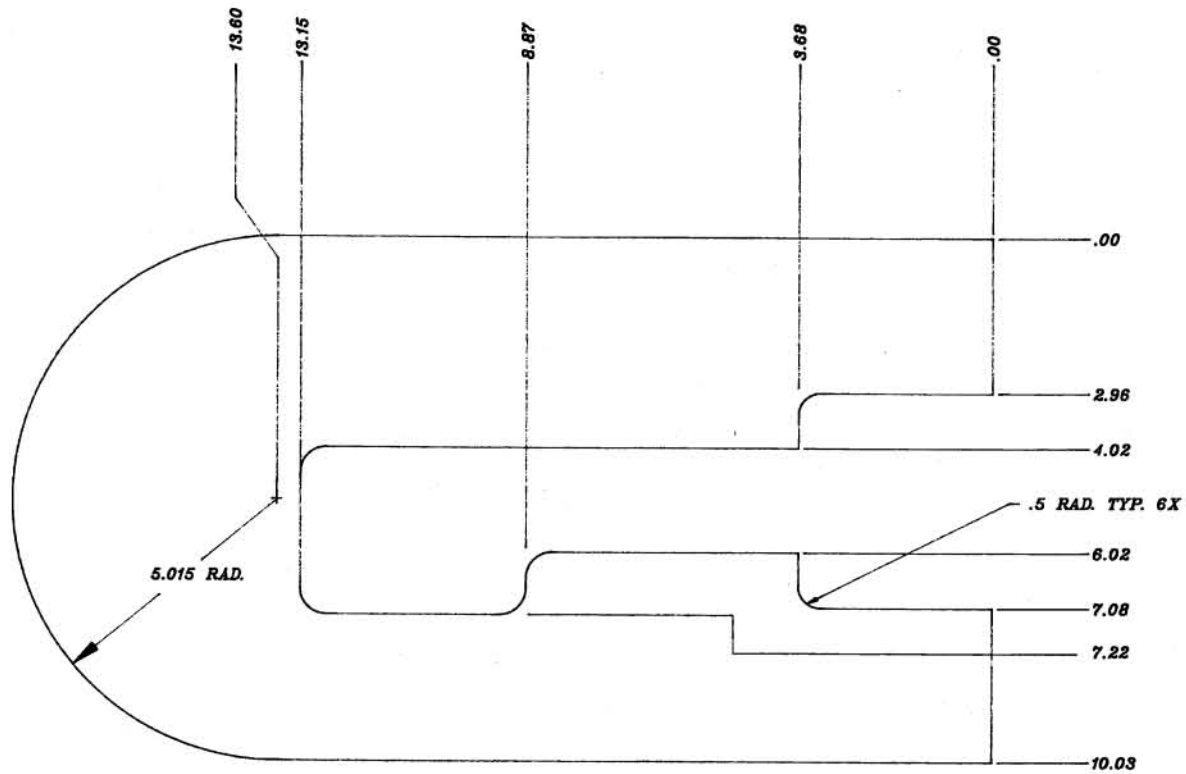

② MAT'L 18 GA. (.0478) STEEL

MATERIAL		DESIGN		ARIEL LIFE SYSTEMS INC. 10110 SORRENTO VALLEY RD. S.D., CA. 92121 (619) 456-5952	
FINISH		APPROVALS	DATE	TITLE	
UNLESS OTHERWISE NOTED ALL DIMENSIONS ARE IN INCHES		HEWITT	8/90	M/F SHROUD	
TELEPHONE		HEWITT	8/90	SIZE: C	DRAWING NO.: 51800
LINEAR: .001	ANGLES: ± 0.1°	DO NOT SCALE DRAWING		SCALE: 1/2	REV: A2
CONC: .005	SCHEMATIC: ± .005	SHEET: 3		OF: 3	
FLATNESS: ± .005	ROUNDNESS: ± .005	SHEET: 3		OF: 3	

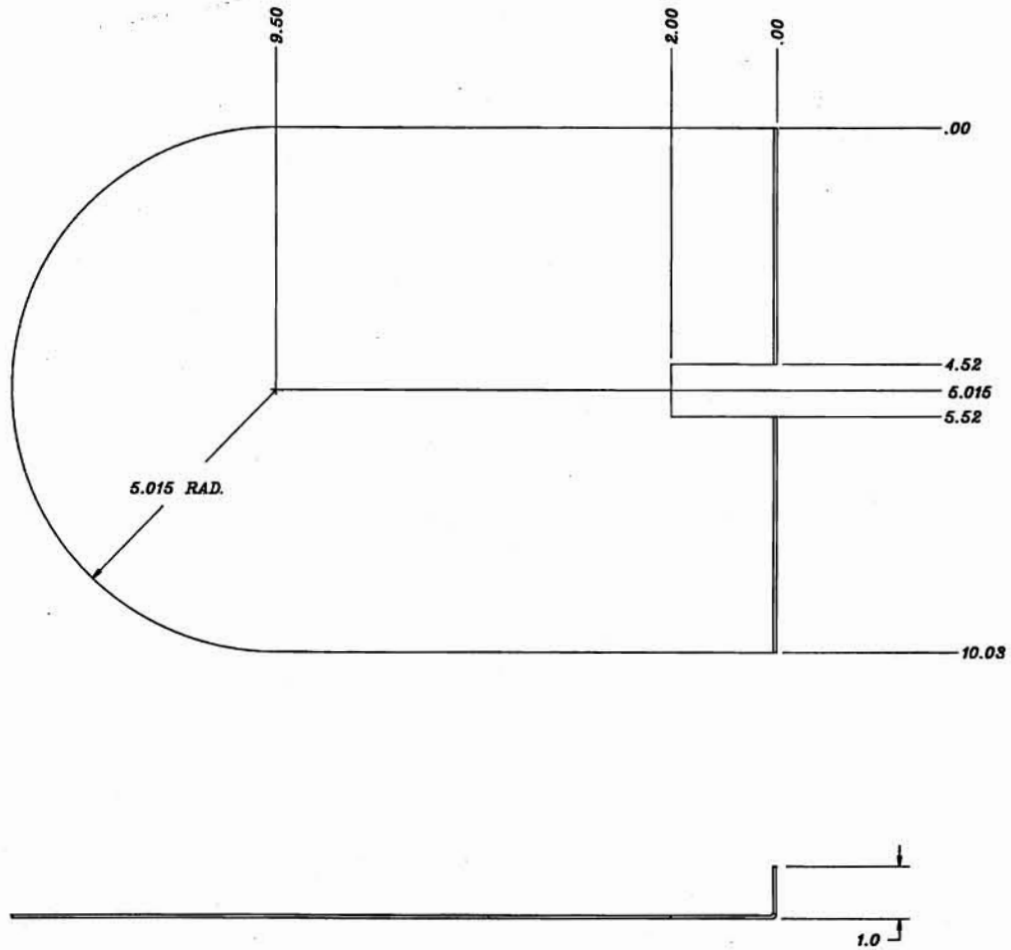

3 MAT'L 18 GA. (.0478) STEEL
1 REQ'D.

MATERIAL:		PART:		ARIEL LIFE SYSTEMS INC. 1010 SORRENTO VALLEY RD. S.D. CA 92121 (619) 455-5952	
UNLESS OTHERWISE NOTED ALL DIMENSIONS ARE IN INCHES TOLERANCES: .001 .001 ANGLES & R/F .001 .001 CONCENTRICITY & POS .0008 .001 FLATNESS & POS .0008 .001 ROUNDNESS & POS		APPROVALS DESIGNER: HEWITT APPROVER: HEWITT	DATE 8/90 8/90	TITLE: M/F SHROUD	
DO NOT SCALE DRAWING		SCALE: 1/2	DRAWING NO.: 51800	REV.: A2	SHEET: 4 OF: